

# SKiiP 13AC12T4V1

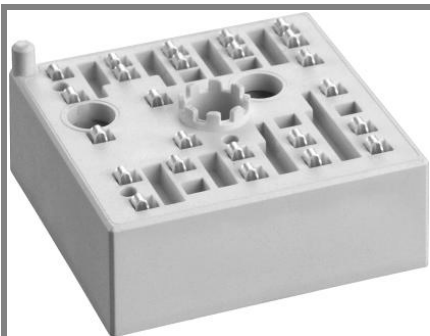

MiniSKiiP<sup>®</sup>1

## 3-phase bridge inverter

### SKiiP 13AC12T4V1

#### Features

- Trench 4 IGBT's
- Robust and soft freewheeling diodes in CAL technology
- Highly reliable spring contacts for electrical connections
- UL recognised file no. E63532

#### Typical Applications\*

- Inverter up to 14 kVA
- Typical motor power 7,5 kW

#### Remarks

- $V_{CEsat}$ ,  $V_F$  = chip level value
- Case temp. limited to  $T_C = 125^\circ\text{C}$  max. (for baseplateless modules  $T_C = T_S$ )
- product rel. results valid for  $T_j \leq 150$  (recomm.  $T_{op} = -40 \dots +150^\circ\text{C}$ )

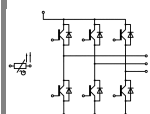

AC

Absolute Maximum Ratings		$T_C = 25^\circ\text{C}$ , unless otherwise specified	
Symbol	Conditions	Values	Units
<b>IGBT</b>			
$V_{CES}$	$T_j = 25^\circ\text{C}$	1200	V
$I_C$	$T_j = 175^\circ\text{C}$	$T_C = 25^\circ\text{C}$	41 A
		$T_C = 70^\circ\text{C}$	34 A
$I_{CRM}$	$I_{CRM} = 3 \times I_{Cnom}$	75	A
$V_{GES}$		$\pm 20$	V
$t_{psc}$	$V_{CC} = 800\text{ V}; V_{GE} \leq 15\text{ V}; T_j = 150^\circ\text{C}$ $V_{CES} < 1200\text{ V}$	10	$\mu\text{s}$
<b>Inverse Diode</b>			
$I_F$	$T_j = 175^\circ\text{C}$	$T_C = 25^\circ\text{C}$	30 A
		$T_C = 70^\circ\text{C}$	26 A
$I_{FRM}$	$I_{CRM} = 3 \times I_{Cnom}$	75	A
$I_{FSM}$	$t_p = 10\text{ ms}; \text{sin.}$	$T_j = 150^\circ\text{C}$	100 A
<b>Module</b>			
$I_{t(RMS)}$		40	A
$T_{vj}$		-40...+175	$^\circ\text{C}$
$T_{stg}$		-40...+125	$^\circ\text{C}$
$V_{isol}$	AC, 1 min.	2500	V

Characteristics		$T_C = 25^\circ\text{C}$ , unless otherwise specified				
Symbol	Conditions	min.	typ.	max.	Units	
<b>IGBT</b>						
$V_{GE(th)}$	$V_{GE} = V_{CE}, I_C = 1\text{ mA}$	5	5,8	6,5	V	
$I_{CES}$	$V_{GE} = V, V_{CE} = V_{CES}$	$T_j = 25^\circ\text{C}$			mA	
			$T_j = 150^\circ\text{C}$	0,8	0,9	V
$V_{CE0}$			0,7	0,8	V	
$r_{CE}$	$V_{GE} = 15\text{ V}$	$T_j = 25^\circ\text{C}$	42	46	$\text{m}\Omega$	
		$T_j = 150^\circ\text{C}$	62	66	$\text{m}\Omega$	
$V_{CE(sat)}$	$I_{Cnom} = 25\text{ A}, V_{GE} = 15\text{ V}$	$T_j = 25^\circ\text{C}_{chiplev.}$	1,85	2,05	V	
		$T_j = 150^\circ\text{C}_{chiplev.}$	2,25	2,45	V	
$C_{ies}$	$V_{CE} = 25, V_{GE} = 0\text{ V}$	$f = 1\text{ MHz}$			nF	
$C_{oes}$					nF	
$C_{res}$					nF	
$Q_G$	$V_{GE} = -8 \dots +15\text{ V}$			140	nC	
$R_{Gint}$	$T_j = 25^\circ\text{C}$			0	$\Omega$	
$t_{d(on)}$	$R_{Gon} = 39\ \Omega$ $di/dt = 465\text{ A}/\mu\text{s}$	$V_{CC} = 600\text{ V}$ $I_C = 25\text{ A}$			44	ns
$t_r$					46	ns
$E_{on}$	$R_{Goff} = 39\ \Omega$ $di/dt = 350\text{ A}/\mu\text{s}$	$T_j = 150^\circ\text{C}$ $V_{GE} = \pm 15\text{ V}$			3,7	mJ
$t_{d(off)}$					330	ns
$t_f$					62	ns
$E_{off}$					2,4	mJ
$R_{th(j-s)}$	per IGBT			1	K/W	

# SKiiP 13AC12T4V1

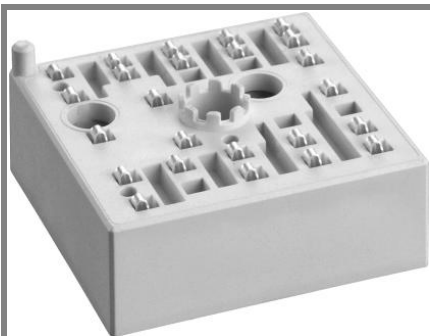

MiniSKiiP<sup>®</sup>1

## 3-phase bridge inverter

### SKiiP 13AC12T4V1

#### Features

- Trench 4 IGBT's
- Robust and soft freewheeling diodes in CAL technology
- Highly reliable spring contacts for electrical connections
- UL recognised file no. E63532

#### Typical Applications\*

- Inverter up to 14 kVA
- Typical motor power 7,5 kW

#### Remarks

- $V_{CEsat}$ ,  $V_F$  = chip level value
- Case temp. limited to  $T_C = 125^\circ\text{C}$  max. (for baseplateless modules  $T_C = T_S$ )
- product rel. results valid for  $T_j \leq 150$  (recomm.  $T_{op} = -40 \dots +150^\circ\text{C}$ )

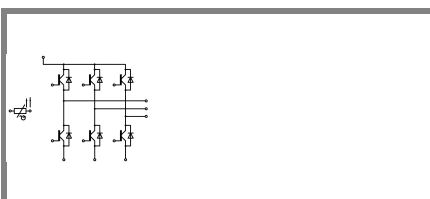

AC

Characteristics						
Symbol	Conditions	min.	typ.	max.	Units	
<b>Inverse Diode</b>						
$V_F = V_{EC}$	$I_{Fnom} = 25 \text{ A}; V_{GE} = 0 \text{ V}$		$T_j = 25^\circ\text{C}_{chiplev.}$	2,4	2,75	V
			$T_j = 150^\circ\text{C}_{chiplev.}$	2,45	2,8	V
$V_{F0}$			$T_j = 25^\circ\text{C}$	1,3	1,5	V
			$T_j = 150^\circ\text{C}$	0,9	1,1	V
$r_F$			$T_j = 25^\circ\text{C}$	44	50	mΩ
			$T_j = 150^\circ\text{C}$	62	68	mΩ
$I_{RRM}$	$I_F = 25 \text{ A}$	$T_j = 150^\circ\text{C}$		19	A	
$Q_{rr}$	$di/dt = 640 \text{ A}/\mu\text{s}$			4	μC	
$E_{rr}$	$V_{GE} = \pm 15 \text{ V}$			1,64	mJ	
$R_{th(j-s)}$	per diode			1,52	K/W	
$M_s$	to heat sink			2	2,5	Nm
w				35		g
<b>Temperature sensor</b>						
$R_{ts}$	3%, $T_r = 25^\circ\text{C}$			1000		Ω
$R_{ts}$	3%, $T_r = 100^\circ\text{C}$			1670		Ω

This is an electrostatic discharge sensitive device (ESDS), international standard IEC 60747-1, Chapter IX.

\* The specifications of our components may not be considered as an assurance of component characteristics. Components have to be tested for the respective application. Adjustments may be necessary. The use of SEMIKRON products in life support appliances and systems is subject to prior specification and written approval by SEMIKRON. We therefore strongly recommend prior consultation of our staff.

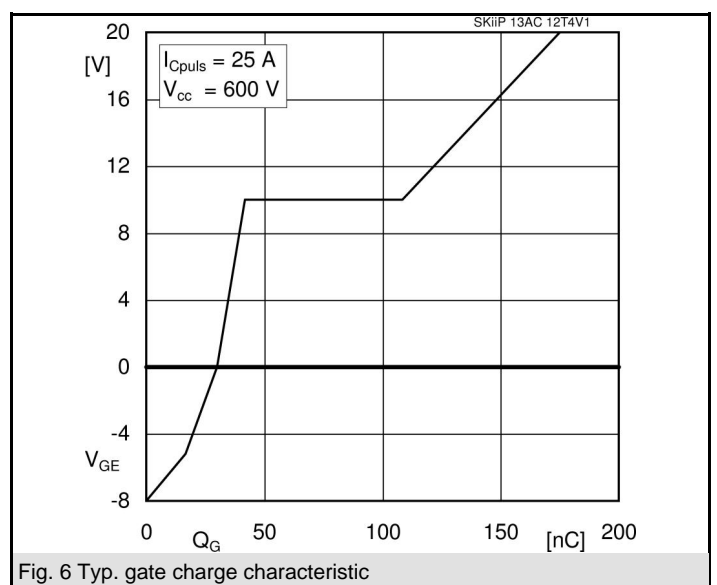
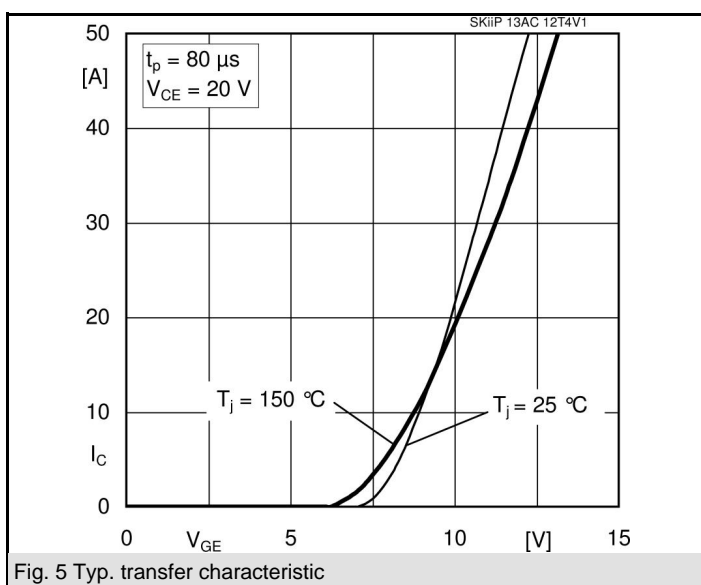
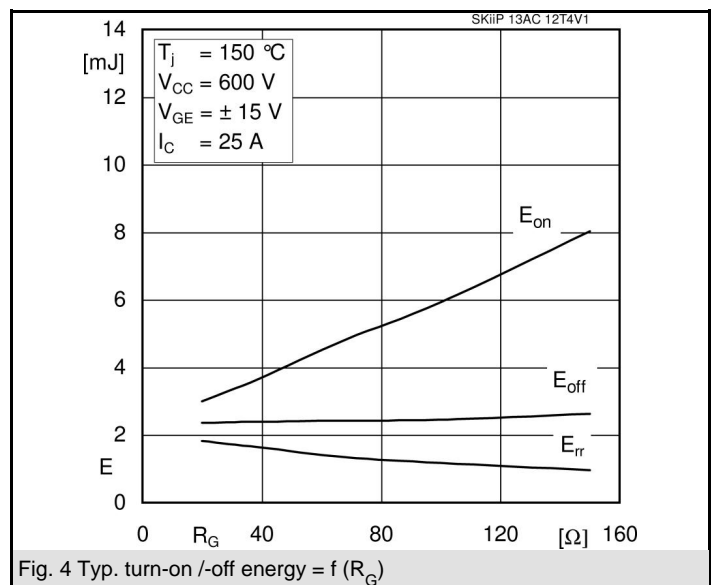
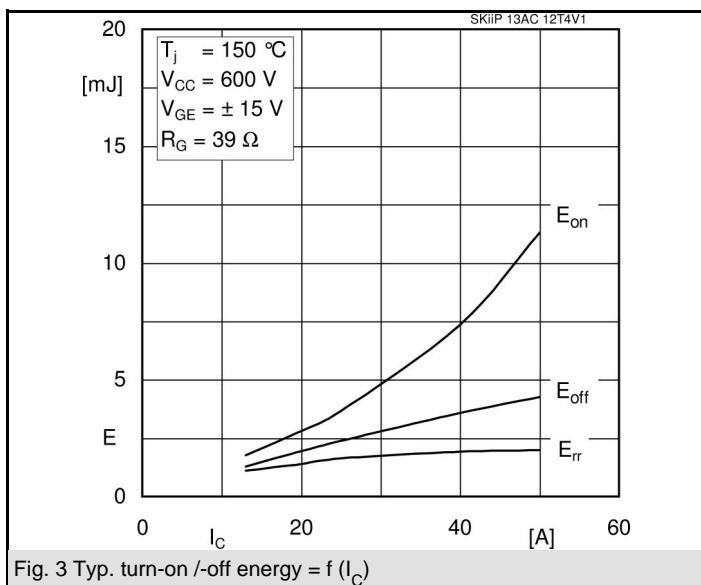
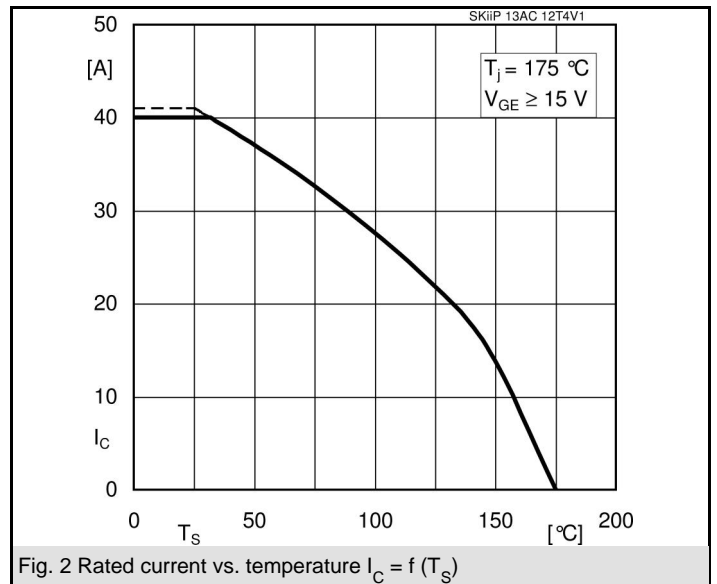
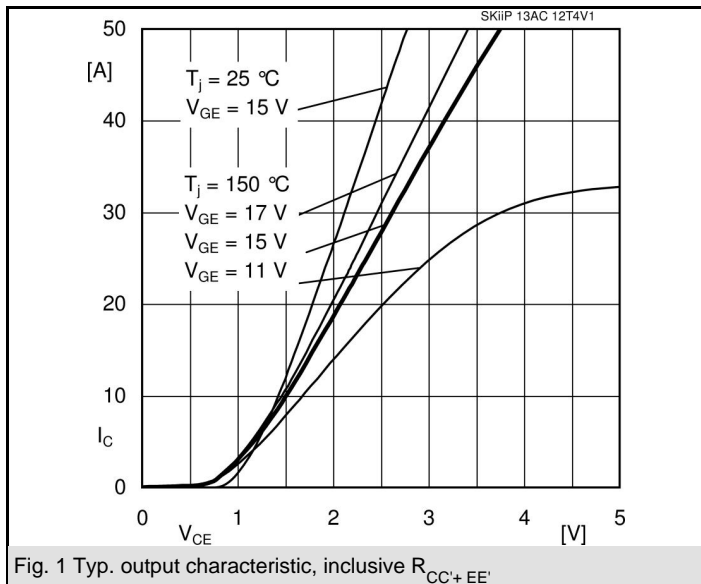

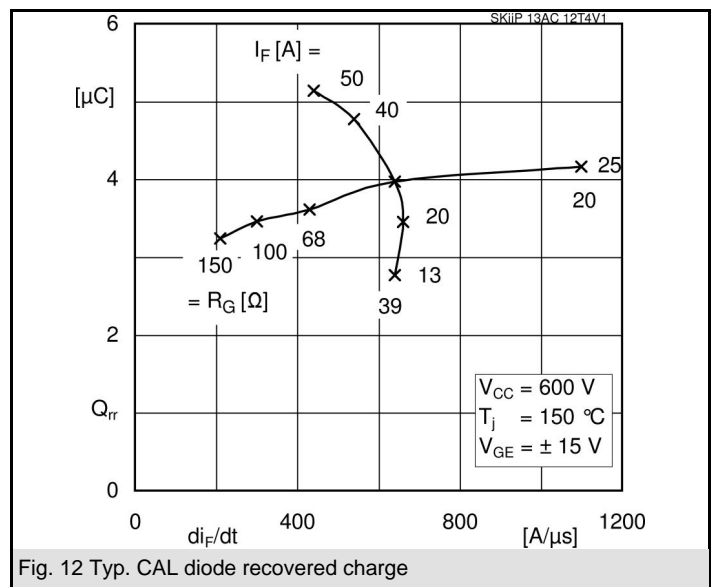
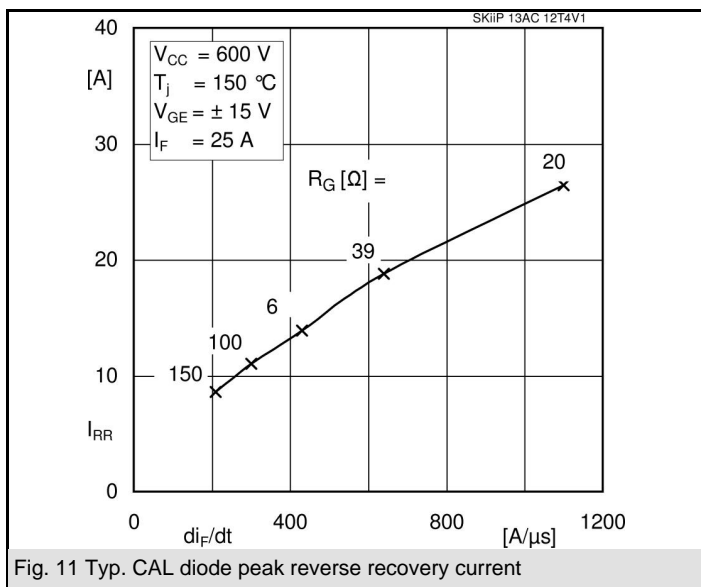
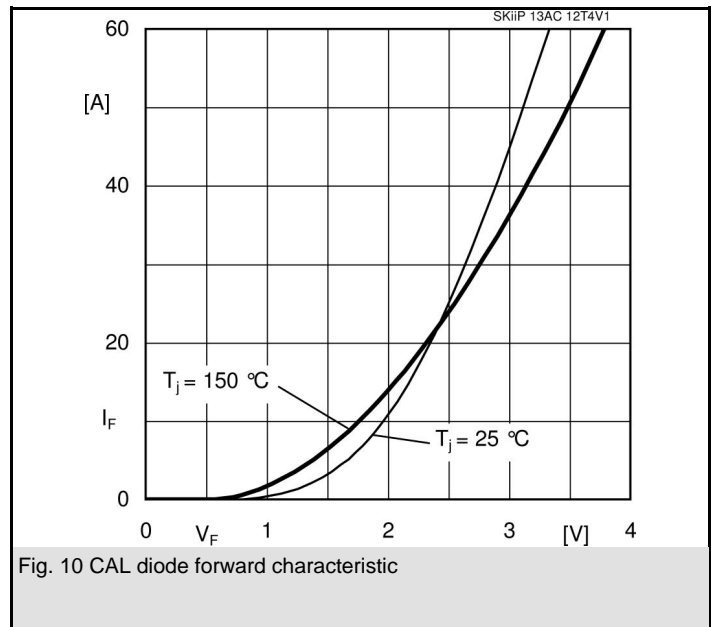
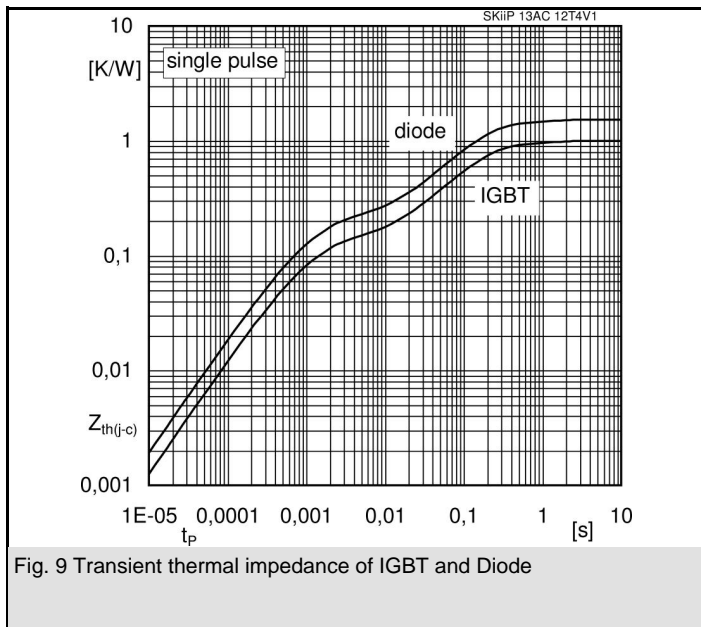
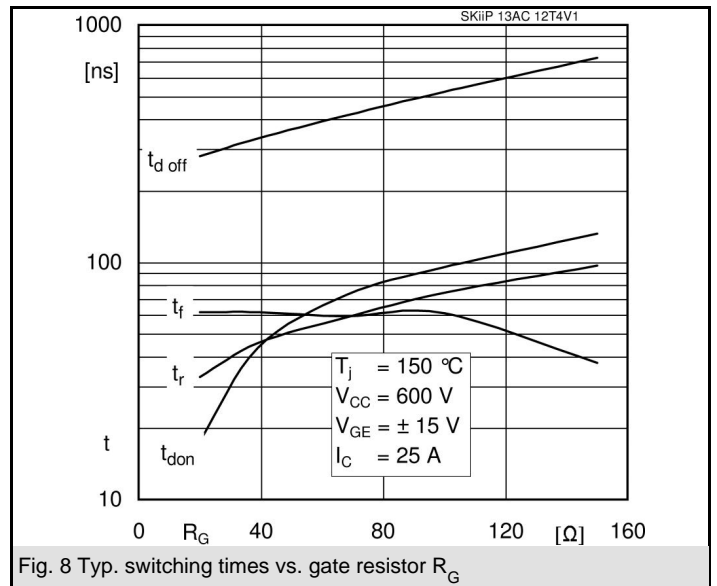
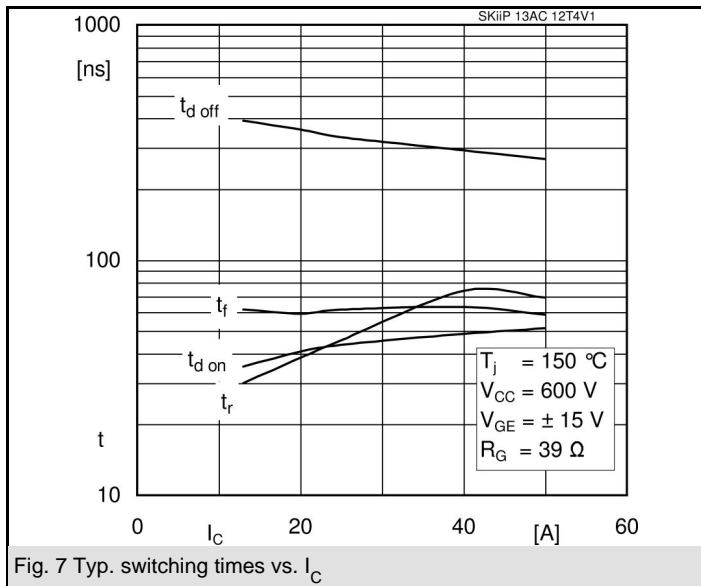

# SKiiP 13AC12T4V1

UL recognized file

no. E 63 532

## PCB PCB TOP-VIEW

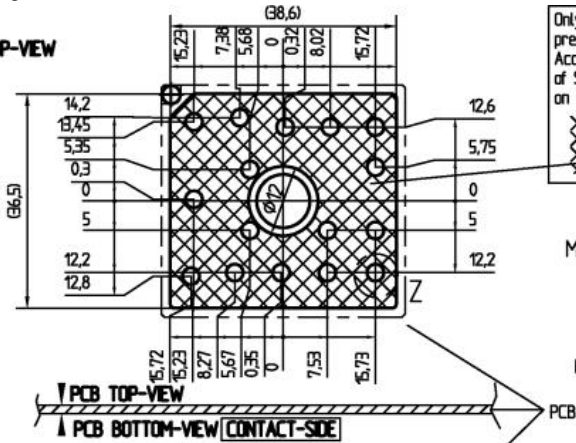

## MiniSKiiP 1

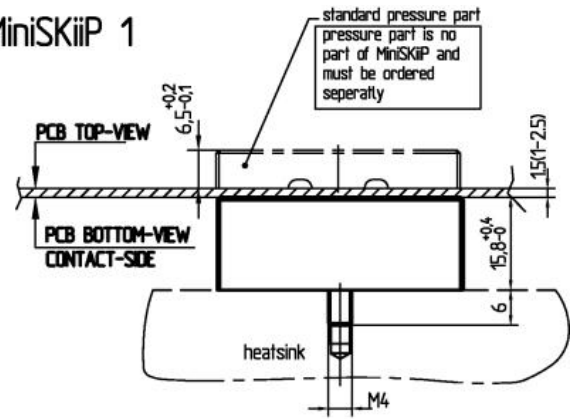

## PCB BOTTOM-VIEW CONTACT-SIDE

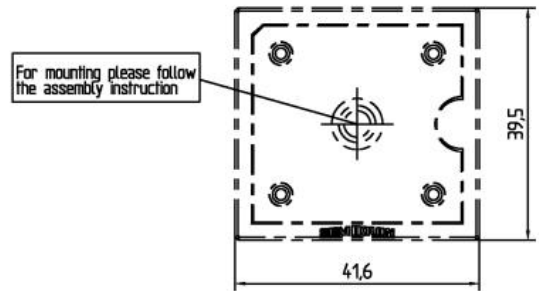
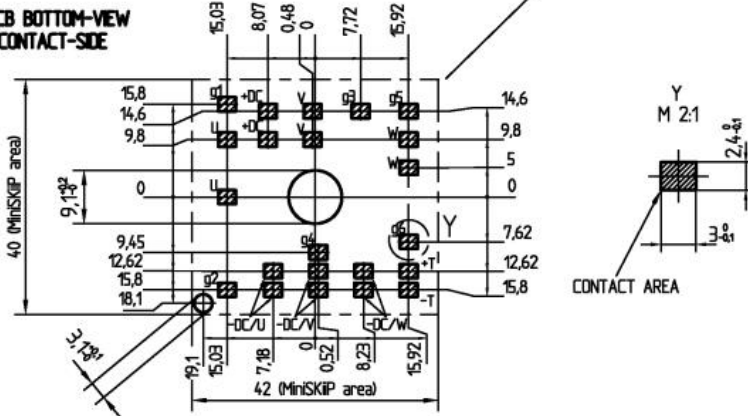

measure: mm  
tolerance: ISO 2768-f

case

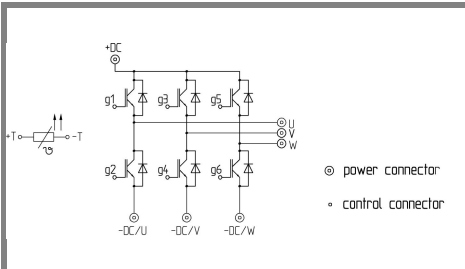

pinout