

2MBI1400VXB-170E-50

IGBT Modules

IGBT MODULE (V series) 1700V / 1400A / 2 in one package

■ Features

- High speed switching
- Voltage drive
- Low Inductance module structure

■ Applications

- Inverter for Motor Drive
- AC and DC Servo Drive Amplifier
- Uninterruptible Power Supply
- Industrial machines, such as Welding machines



■ Maximum Ratings and Characteristics

● Absolute Maximum Ratings (at Tc=25°C unless otherwise specified)

Items	Symbols	Conditions	Maximum ratings	Units	
Inverter	Collector-Emitter voltage	V _{CEs}	1700	V	
	Gate-Emitter voltage	V _{GES}	±20	V	
	Collector current	I _c	Continuous	T _c =25°C 1800 T _c =100°C 1400	A
		I _{c pulse}	1ms	2800	
		-I _c		1400	
		-I _{c pulse}	1ms	2800	
		Collector power dissipation	P _c	1 device	
Junction temperature	T _j		175	°C	
Operating junction temperature (under switching conditions)	T _{top}		150		
Case temperature	T _c		150		
Storage temperature	T _{stg}		-40 ~ +150		
Isolation voltage	between terminal and copper base (*1)	V _{iso}	AC : 1min.	4000	VAC
	between thermistor and others (*2)				
Screw torque (*3)	Mounting		M5	6.0	N m
	Main Terminals		M8	10.0	
	Sense Terminals		M4	2.1	

Note *1: All terminals should be connected together during the test.

Note *2: Two thermistor terminals should be connected together, other terminals should be connected together and shorted to base plate during the test.

Note *3: Recommendable Value : Mounting 3.0 ~ 6.0 Nm (M5) Recommendable Value : Main Terminals 8.0 ~ 10.0 Nm (M8)
Recommendable Value : Sense Terminals 1.8 ~ 2.1 Nm (M4)

● Electrical characteristics (at Tj= 25°C unless otherwise specified)

Items	Symbols	Conditions	Characteristics			Units		
			min.	typ.	max.			
Inverter	Zero gate voltage collector current	I _{CEs}	V _{GE} = 0V, V _{CE} = 1700V	-	-	12.0	mA	
	Gate-Emitter leakage current	I _{GES}	V _{CE} = 0V, V _{GE} = ±20V	-	-	2400	nA	
	Gate-Emitter threshold voltage	V _{GE(th)}	V _{CE} = 20V, I _c = 1400mA	6.0	6.5	7.0	V	
	Collector-Emitter saturation voltage	V _{CE(sat)} (terminal) (*4)	V _{GE} = 15V I _c = 1400A	T _j =25°C	-	2.35	2.80	V
				T _j =125°C	-	2.85	-	
				T _j =150°C	-	2.95	-	
				T _j =25°C	-	2.15	2.60	
				T _j =125°C	-	2.65	-	
	Internal gate resistance	R _{g(int)}	-	-	2.25	-	Ω	
	Input capacitance	C _{ies}	V _{CE} = 10V, V _{GE} = 0V, f = 1MHz	-	113	-	nF	
	Turn-on time	ton	V _{CC} =900V, I _c =1400A, V _{GE} =±15V, R _θ =+0.47/-0.68Ω, L _s =40nH	-	1350	-	nsec	
		tr		-	300	-		
		tr (i)		-	150	-		
	Turn-off time	toff	-	-	1600	-	nsec	
		tf	-	-	150	-		
Forward on voltage	V _F (terminal) (*4)	V _{GE} = 0V I _F = 1400A	T _j =25°C	-	2.00	2.45	V	
			T _j =125°C	-	2.25	-		
			T _j =150°C	-	2.20	-		
			T _j =25°C	-	1.80	2.25		
			T _j =125°C	-	2.05	-		
Reverse recovery time	t _{rr}	I _F = 1400A	-	250	-	nsec		
Thermistor	Resistance	R	T=25°C	-	5000	-	Ω	
	B value	B	T=25/50°C	3305	3375	3450	K	

Note *4: Please refer to Page 6 , there is definition of on-state voltage at terminal.

● Thermal resistance characteristics

Items	Symbols	Conditions	Characteristics			Units
			min.	typ.	max.	
Thermal resistance (1device)	R _{th(j-c)}	Inverter IGBT	-	-	0.017	°C/W
		Inverter FWD	-	-	0.032	
Contact thermal resistance (1device) (*5)	R _{th(c-f)}	with Thermal Compound	-	0.0042	-	

Note *5: This is the value which is defined mounting on the additional cooling fin with thermal compound.

■ Characteristics (Representative)

[INVERTER]

Collector current vs. Collector-Emittter voltage (typ.)
Tj= 25°C / chip

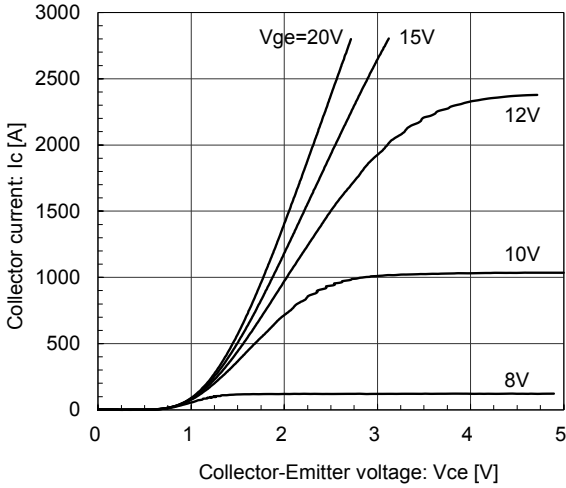

[INVERTER]

Collector current vs. Collector-Emittter voltage (typ.)
Tj= 150°C / chip

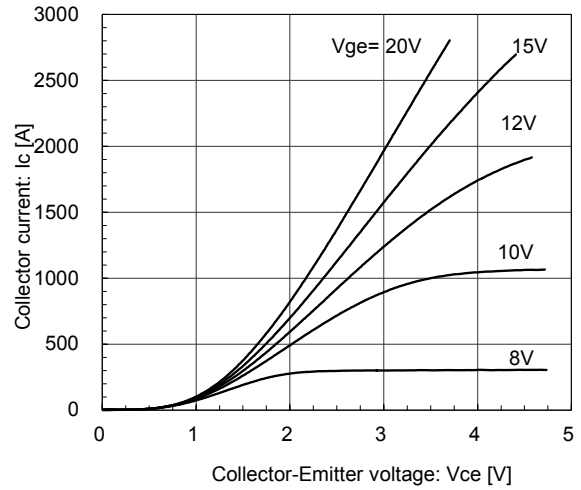

[INVERTER]

Collector current vs. Collector-Emittter voltage (typ.)
Vge= 15V / chip

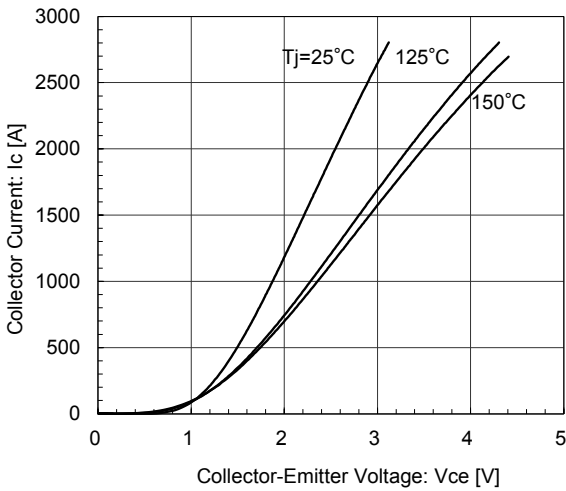

[INVERTER]

Collector-Emittter voltage vs. Gate-Emittter voltage (typ.)
Tj= 25°C / chip

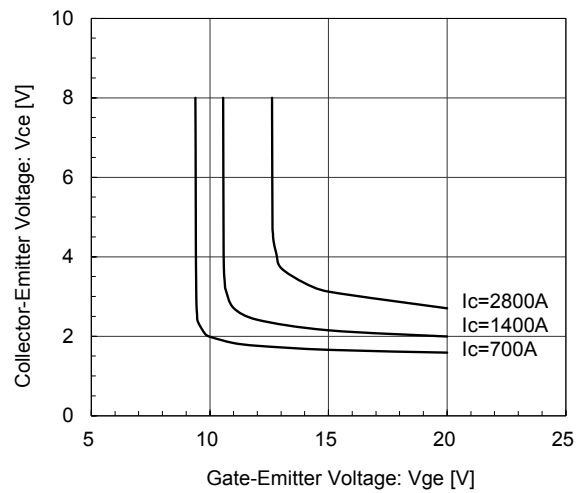

[INVERTER]

Gate Capacitance vs. Collector-Emittter Voltage (typ.)
Vge= 0V, f= 1MHz, Tj= 25°C

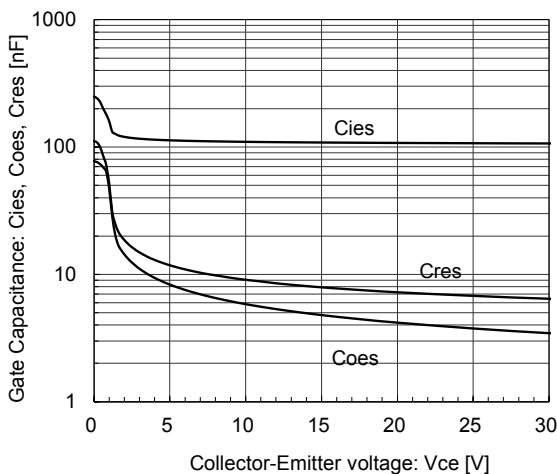

[INVERTER]

Dynamic Gate Charge (typ.)
Vcc=900V, Ic=1400A, Tj= 25°C

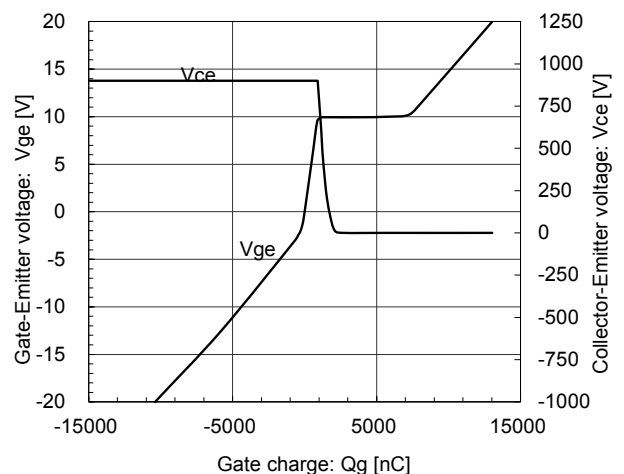

[INVERTER]

Switching time vs. Collector current (typ.)

V_{cc}=900V, V_{ge}=±15V, R_g=+0.47/-0.68Ω, T_j=25°C

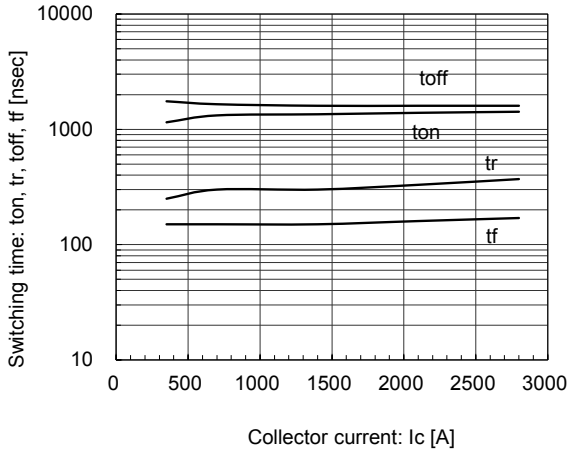

[INVERTER]

Switching time vs. Collector current (typ.)

V_{cc}=900V, V_{ge}=±15V, R_g=+0.47/-0.68Ω, T_j=125°C, 150°C

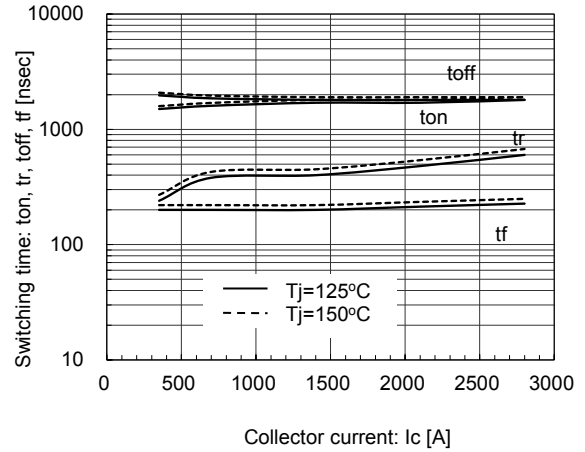

[INVERTER]

Switching time vs. Gate resistance (typ.)

V_{cc}=900V, I_c=1400A, V_{ge}=±15V, T_j=125°C, 150°C

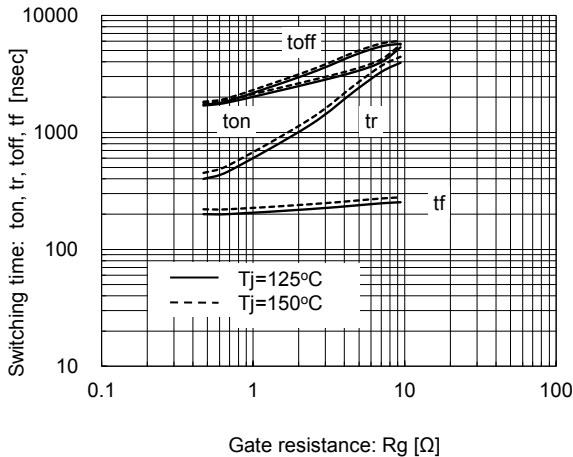

[INVERTER]

Switching loss vs. Collector current (typ.)

V_{cc}=900V, V_{ge}=±15V, R_g=+0.47/-0.68Ω, T_j=125°C, 150°C

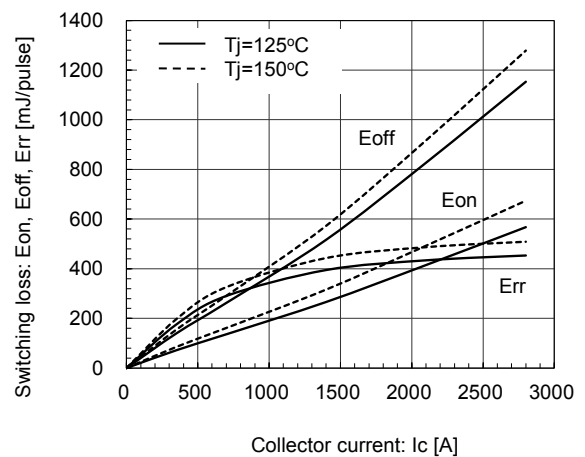

[INVERTER]

Switching loss vs. Gate resistance (typ.)

V_{cc}=900V, I_c=1400A, V_{ge}=±15V, T_j=125°C, 150°C

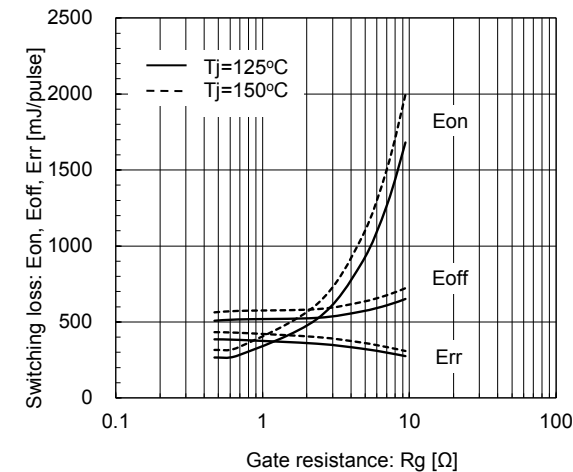

[INVERTER]

Reverse bias safe operating area (max.)

+V_{ge}=15V, -V_{ge}=15V, R_g=+0.47/-0.68Ω, T_j=150°C

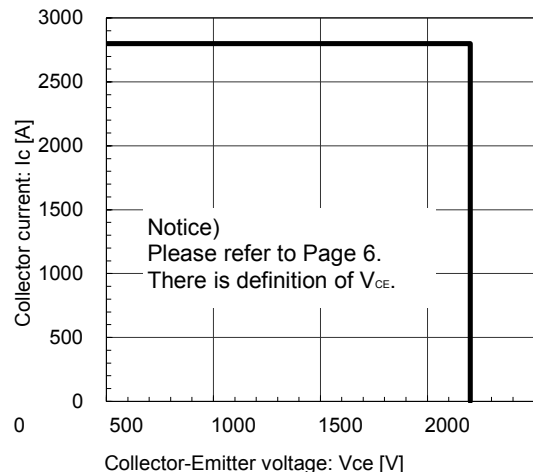

[INVERTER]

Forward Current vs. Forward Voltage (typ.)
chip

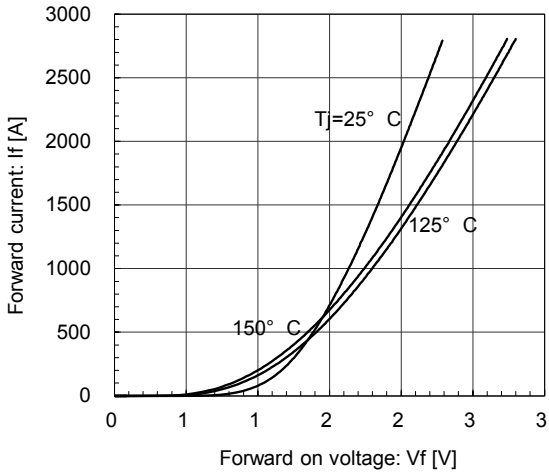

[INVERTER]

Reverse Recovery Characteristics (typ.)
Vcc=900V, Vge=±15V, Rg=+0.47/-0.68Ω, Tj=25°C

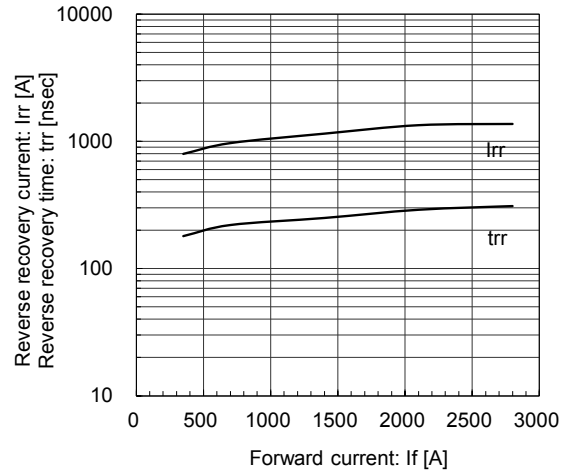

[INVERTER]

Reverse Recovery Characteristics (typ.)

Vcc=900V, Vge=±15V, Rg=+0.47/-0.68Ω, Tj=125°C, 150°C

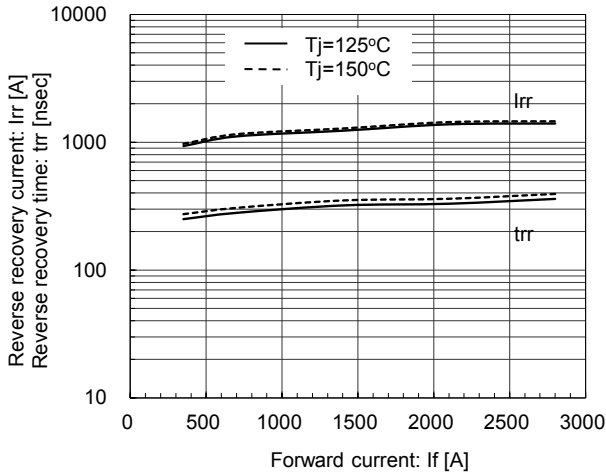

Transient Thermal Resistance (max.)

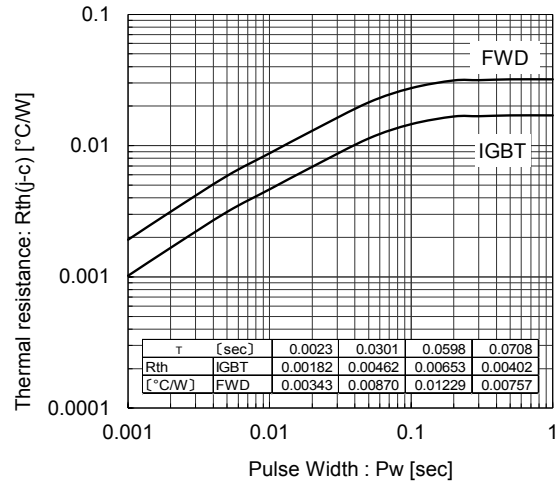

[THERMISTOR]

Temperature characteristic (typ.)

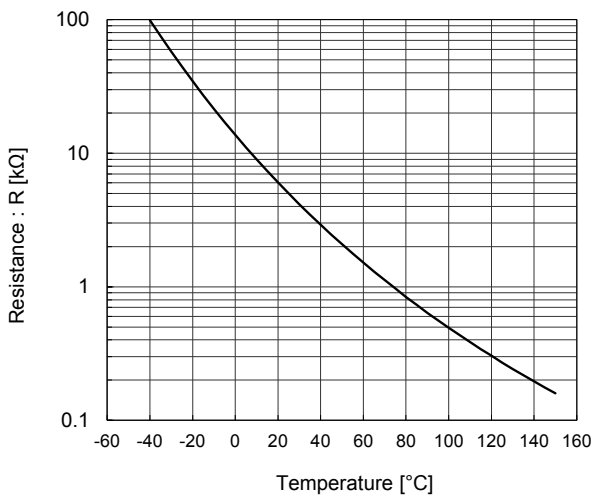

FWD safe operating area (max.)

Tj=150°C

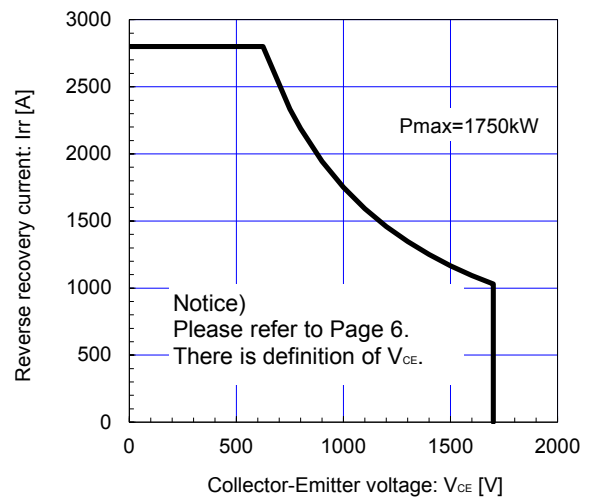

■ Outline Drawings, mm

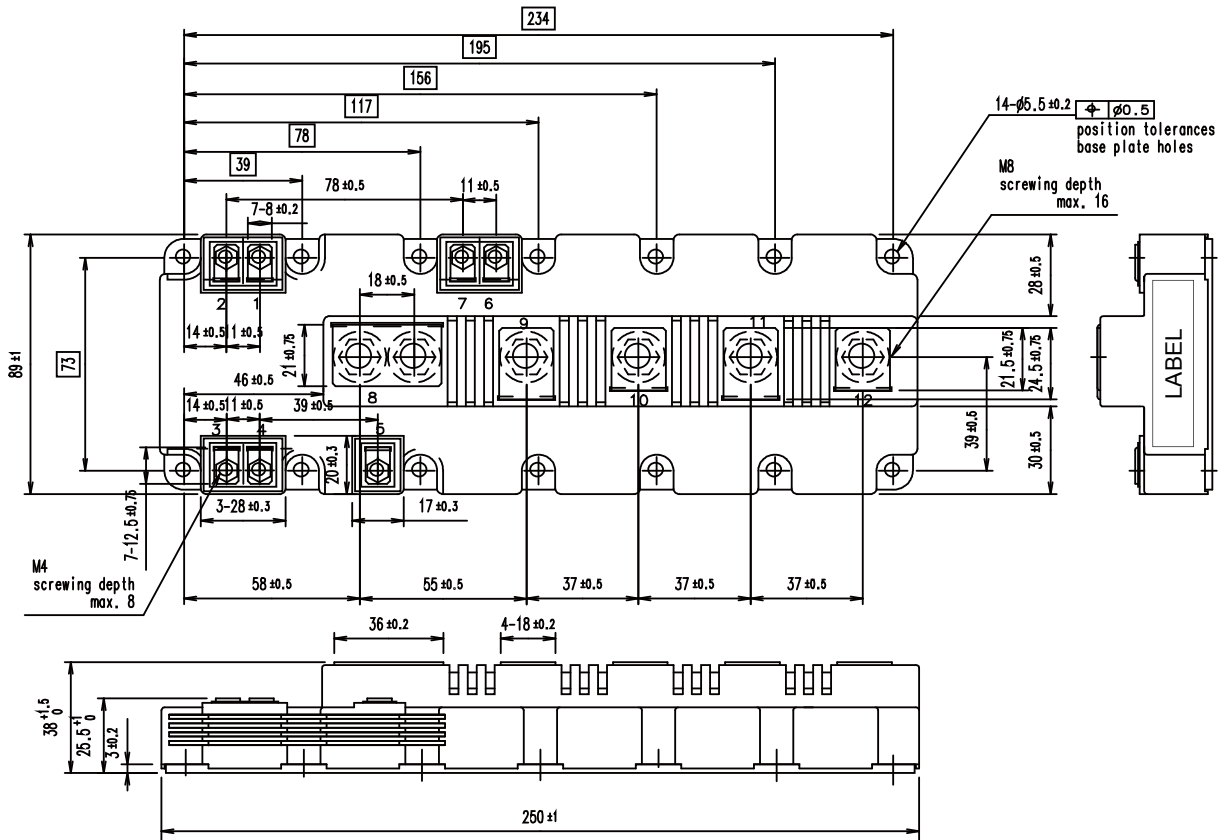

Weight: 1250g(typ.)

■ Equivalent Circuit Schematic

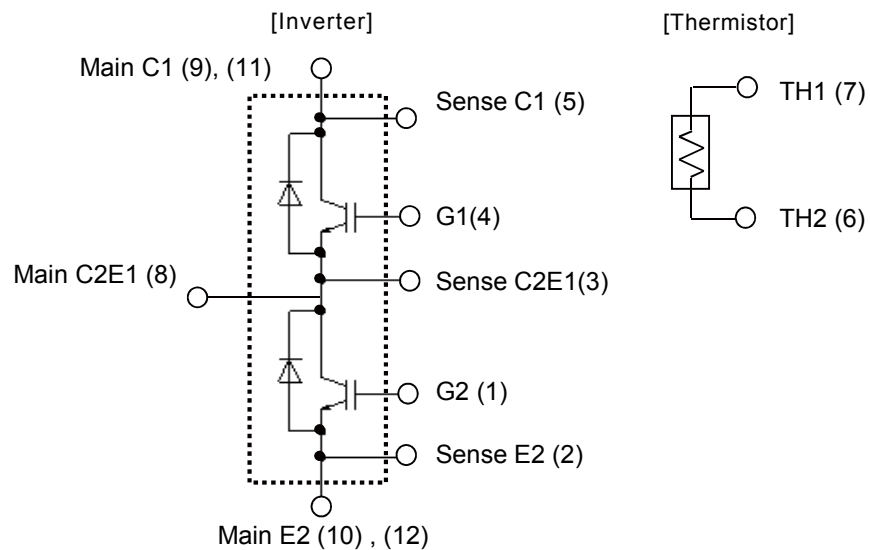

■ Definition of on-state voltage at terminal and switching characteristics

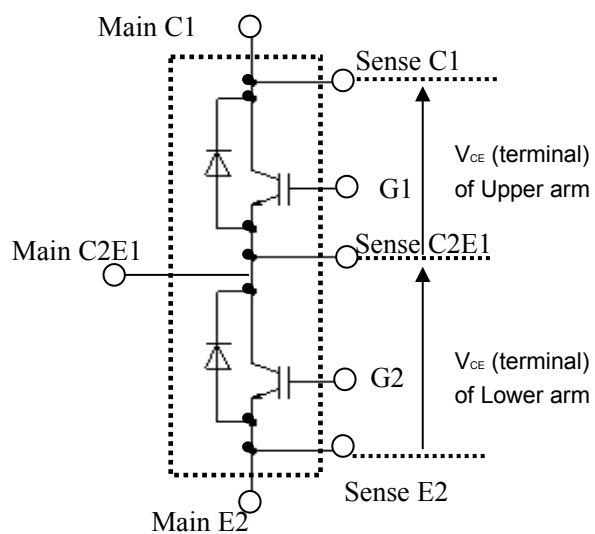

Fuji defined V_{CE} value of terminal by using Sense C1 and Sense C2E1 for Upper arm and Sense C2E1 and Sense E2 for Lower arm .

Switching characteristics of V_{CE} also is defined between Sense C1 and Sense C2E1 for Upper arm and Sense C2E1 and Sense E2 for Lower arm .

Please use these terminals whenever measure spike voltage and on-state voltage .