

# 2MBI300XBE065-50

IGBT Modules

**Power Module (X series)**  
**650V / 300A / 2-in-1 package**

■ **Features**

- Low  $V_{CE(sat)}$
- High speed switching
- Low Inductance Module structure

■ **Applications**

- Inverter for Motor Drives, AC and DC Servo Drives
- Uninterruptible Power Supply Systems,
- Industrial machines, such as Welding machines

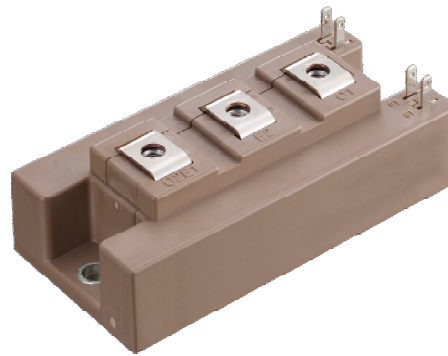

■ **Outline drawing ( Unit : mm )**

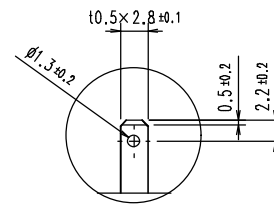
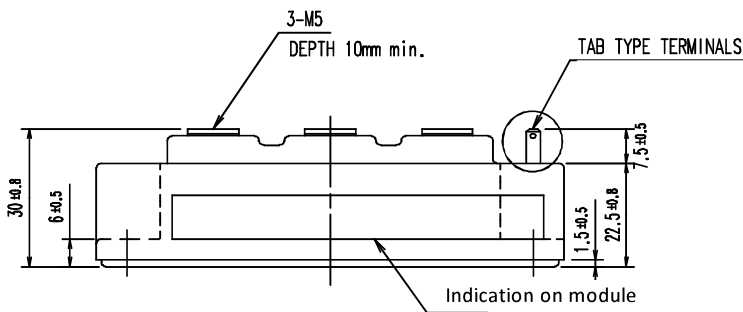
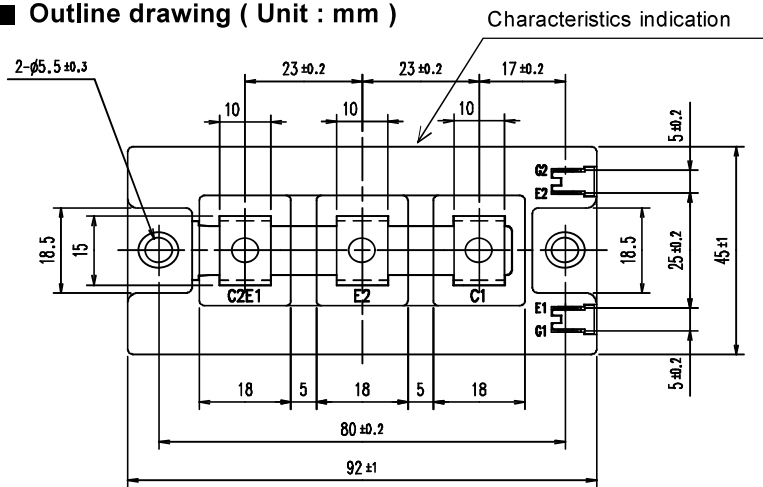

DETAIL TAB TYPE TERMINALS

Weight: 240 g(typ.)

■ **Equivalent circuit**

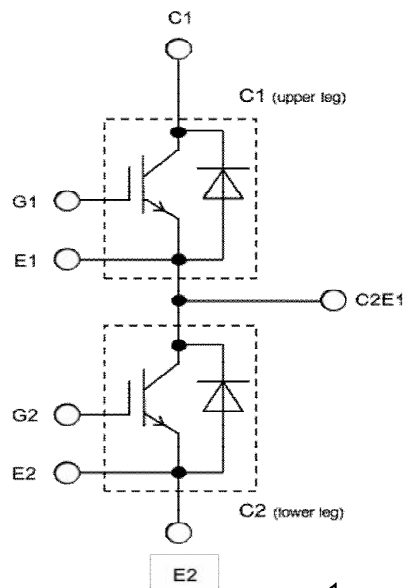

# 2MBI300XBE065-50

IGBT Modules

■ Absolute maximum ratings (at  $T_c = 25^\circ\text{C}$  unless otherwise specified)

Items		Symbols	Conditions	Maximum ratings	Units	
Inverter	Collector-Emitter voltage	$V_{CES}$		650	V	
	Gate-Emitter voltage	$V_{GES}$		$\pm 20$	V	
	Collector current	$I_C$	Continuous $T_c = 100^\circ\text{C}$	300	A	
	Repetitive peak collector current	$I_{CRM}$	1ms	600		
	Forward current	$I_F$		300		
	Repetitive peak forward current	$I_{FRM}$	1ms	600		
	Total power dissipation		$P_{tot}$	1 device	1160	W
	Virtual junction temperature		$T_{vj}$		175	$^\circ\text{C}$
	Operating virtual junction temperature		$T_{vjop}$		175	
	Case temperature		$T_c$		125	
Storage temperature		$T_{stg}$		-40 ~ 125		
Isolation voltage	Between terminal and copper base (*1)	$V_{isol}$	AC: 1min.	4000	Vrms	
Mounting torque of screws to heat sink		$M_s$	M5	2.5 ~ 3.5	N m	
Mounting torque of screws to terminals		$M_t$	M5	2.5 ~ 3.5		

(\*1) All terminals should be connected together during the test.

# 2MBI300XBE065-50

IGBT Modules

■ Electrical characteristics (at  $T_{vj} = 25^\circ\text{C}$  unless otherwise specified)

Items	Symbols	Conditions	Characteristics			Units			
			min.	typ.	max.				
Collector-Emitter cut-off current Gate-Emitter short-circuited	$I_{CES}$	$V_{GE} = 0V$ $V_{CE} = 650V$	-	-	100	$\mu\text{A}$			
Gate leakage current, Collector-Emitter short-circuited	$I_{GES}$	$V_{CE}=0V, V_{GE}=\pm 20V$	-	-	200	nA			
Gate-Emitter threshold voltage	$V_{GE(th)}$	$V_{CE} = 20V$ $I_C = 300\text{mA}$	6.0	6.5	7.0	V			
Collector-Emitter saturation voltage	$V_{CE(sat)}$ (terminal)	$V_{GE} = 15V$ $I_C = 300A$	$T_{vj}=25^\circ\text{C}$	-	1.50	1.95	V		
			$T_{vj}=25^\circ\text{C}$	-	1.30	1.75			
	$T_{vj}=125^\circ\text{C}$		-	1.45	-				
	$T_{vj}=150^\circ\text{C}$		-	1.50	-				
	$T_{vj}=175^\circ\text{C}$		-	1.55	-				
Internal gate resistance	$r_g$	-	-	-	2.25	-	$\Omega$		
			Capacitance	$C_{ies}$	$V_{CE}=10V, V_{GE}=0V, f=1\text{MHz}$	-	34	-	nF
						$C_{oes}$	-	1.3	
$C_{fes}$	-	0.47					-		
Gate charge	$Q_G$	$V_{CC} = 300V, I_C = 300A$ $V_{GE} = -15 \rightarrow +15V$	-	2.4	-	$\mu\text{C}$			
Forward voltage	$V_F$ (terminal)	$V_{GE} = 0V$ $I_F = 300A$	$T_{vj}=25^\circ\text{C}$	-	1.75	2.20	V		
			$T_{vj}=25^\circ\text{C}$	-	1.55	2.00			
	$T_{vj}=125^\circ\text{C}$		-	1.50	-				
	$T_{vj}=150^\circ\text{C}$		-	1.50	-				
	$T_{vj}=175^\circ\text{C}$		-	1.45	-				
Switching time (*1)	$t_{d(on)}$	$V_{CC} = 300V$ $I_C, I_F = 300A$ $V_{GE} = +15/-15V$ $R_G = 4.7 \Omega$ $L_S = 30 \text{ nH}$	$T_{vj}=25^\circ\text{C}$	-	0.37	-	$\mu\text{s}$		
			$T_{vj}=125^\circ\text{C}$	-	0.41	-			
			$T_{vj}=150^\circ\text{C}$	-	0.42	-			
			$T_{vj}=175^\circ\text{C}$	-	0.43	-			
	$t_r$		$T_{vj}=25^\circ\text{C}$	-	0.12	-			
			$T_{vj}=125^\circ\text{C}$	-	0.14	-			
			$T_{vj}=150^\circ\text{C}$	-	0.14	-			
			$T_{vj}=175^\circ\text{C}$	-	0.15	-			
	$t_{d(off)}$		$T_{vj}=25^\circ\text{C}$	-	0.35	-			
			$T_{vj}=125^\circ\text{C}$	-	0.37	-			
			$T_{vj}=150^\circ\text{C}$	-	0.38	-			
			$T_{vj}=175^\circ\text{C}$	-	0.38	-			
	$t_f$		$T_{vj}=25^\circ\text{C}$	-	0.07	-			
			$T_{vj}=125^\circ\text{C}$	-	0.09	-			
			$T_{vj}=150^\circ\text{C}$	-	0.10	-			
			$T_{vj}=175^\circ\text{C}$	-	0.10	-			
Reverse recovery time	$t_{rr}$	$T_{vj}=25^\circ\text{C}$	-	0.08	-				
		$T_{vj}=125^\circ\text{C}$	-	0.15	-				
		$T_{vj}=150^\circ\text{C}$	-	0.16	-				
		$T_{vj}=175^\circ\text{C}$	-	0.18	-				

(\*1) Turn on time ( $t_{on}$ ) =  $t_{d(on)} + t_r$ , Turn off time ( $t_{off}$ ) =  $t_{d(off)} + t_f$

# 2MBI300XBE065-50

**IGBT Modules**
**■ Electrical characteristics (at  $T_{vj}=25^{\circ}\text{C}$  unless otherwise specified)**

Items	Symbols	Conditions	Characteristics			Units	
			min.	typ.	max.		
Inverter Switching loss (per pulse)	$E_{on}$	$V_{CC} = 300\text{V}$	$T_{vj}=25^{\circ}\text{C}$	-	8.9	-	mJ
		$I_C, I_F = 300\text{A}$	$T_{vj}=125^{\circ}\text{C}$	-	16.1	-	
			$T_{vj}=150^{\circ}\text{C}$	-	17.9	-	
			$T_{vj}=175^{\circ}\text{C}$	-	19.7	-	
	$E_{off}$	$V_{GE} = +15/-15\text{V}$	$T_{vj}=25^{\circ}\text{C}$	-	12.5	-	
			$T_{vj}=125^{\circ}\text{C}$	-	13.8	-	
			$T_{vj}=150^{\circ}\text{C}$	-	14.1	-	
			$T_{vj}=175^{\circ}\text{C}$	-	14.4	-	
	$E_{rr}$	$R_G = 4.7\ \Omega$	$T_{vj}=25^{\circ}\text{C}$	-	1.5	-	
			$T_{vj}=125^{\circ}\text{C}$	-	2.5	-	
$T_{vj}=150^{\circ}\text{C}$			-	2.8	-		
$T_{vj}=175^{\circ}\text{C}$			-	3.1	-		

**NOTICE:**

The external gate resistance ( $R_G$ ) shown above is one of our recommended value for the purpose of minimum switching loss. However the optimum  $R_G$  depends on circuit configuration and/or environment. We recommend that the  $R_G$  has to be carefully chosen based on consideration if IGBT module matches design criteria, for example, switching loss, EMC/EMI, spike voltage, surge current and no unexpected oscillation and so on.

**■ Thermal resistance characteristics**

	Symbols	Conditions	Characteristics			Units
			min.	typ.	max.	
Thermal resistance junction to case (1 device)	$R_{th(j-c)}$	Inverter IGBT	-	-	0.129	K/W
		Inverter FWD	-	-	0.174	
Thermal resistance case to heat sink (1 IGBT + 1FWD) (*1)	$R_{th(c-s)}$	with 1 W/(m·K) thermal grease	-	0.0250	-	

(\*1) This is the value which is defined mounting on the additional cooling fin with thermal compound.

# 2MBI300XBE065-50

IGBT Modules

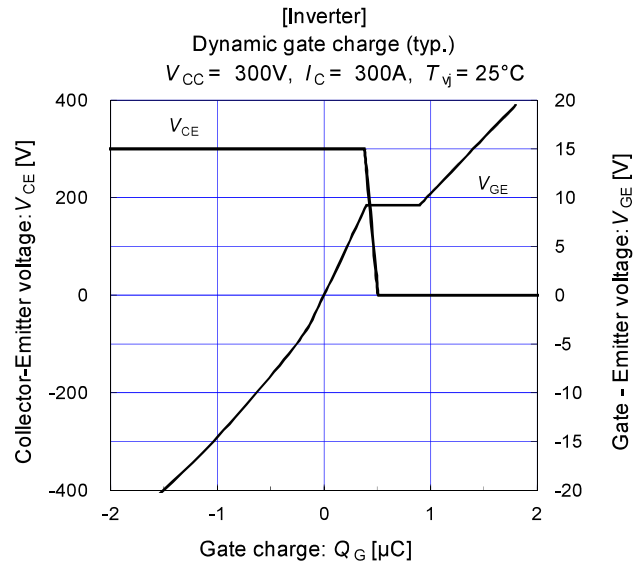
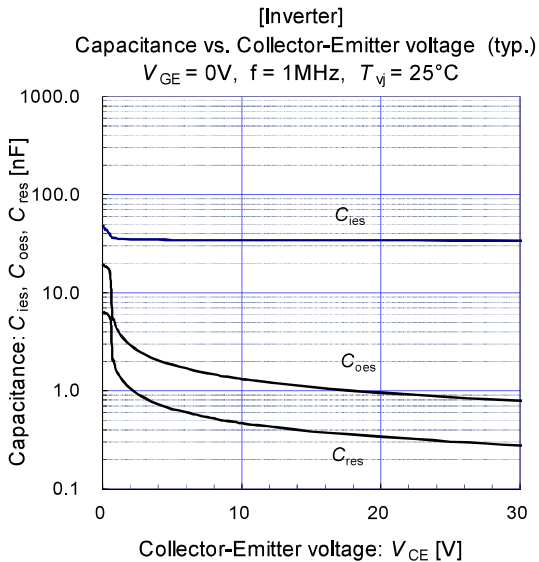
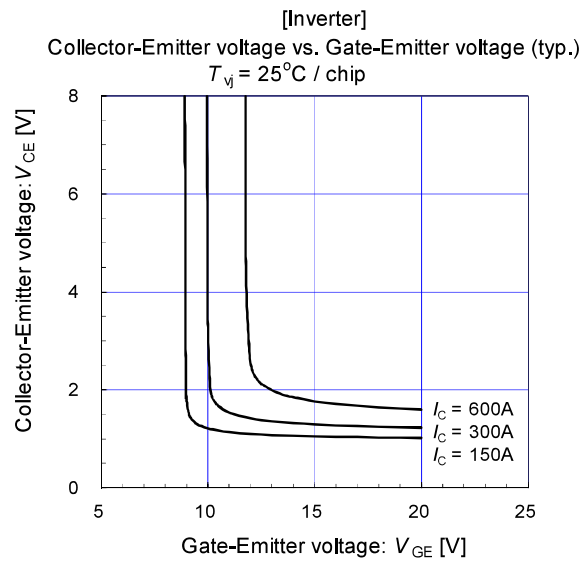
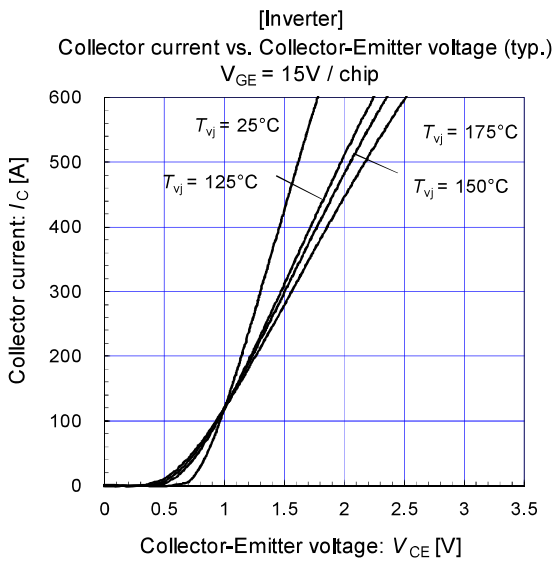
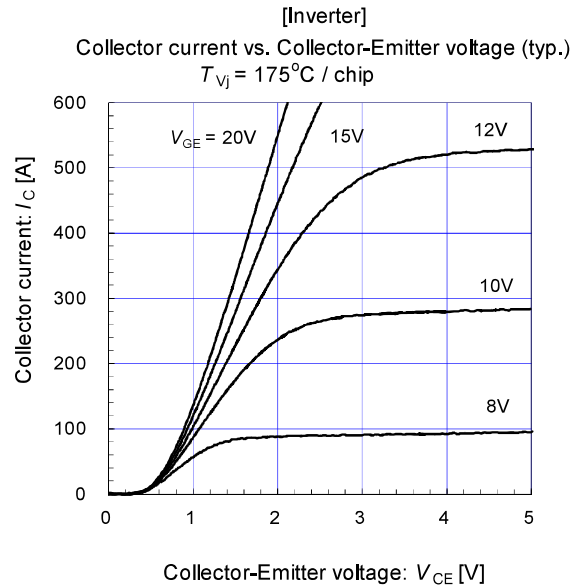
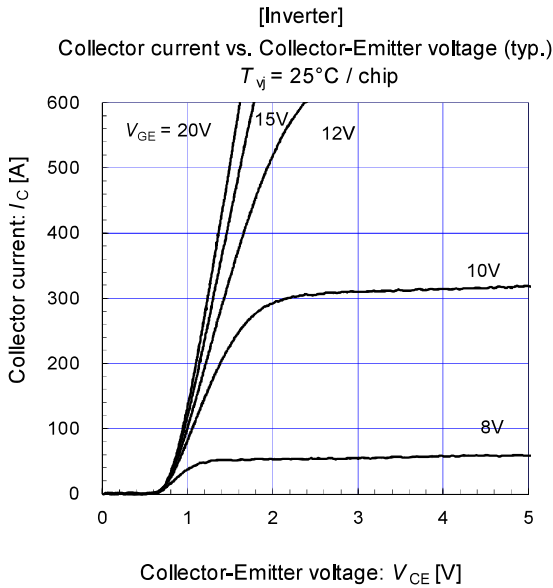

# 2MBI300XBE065-50

IGBT Modules

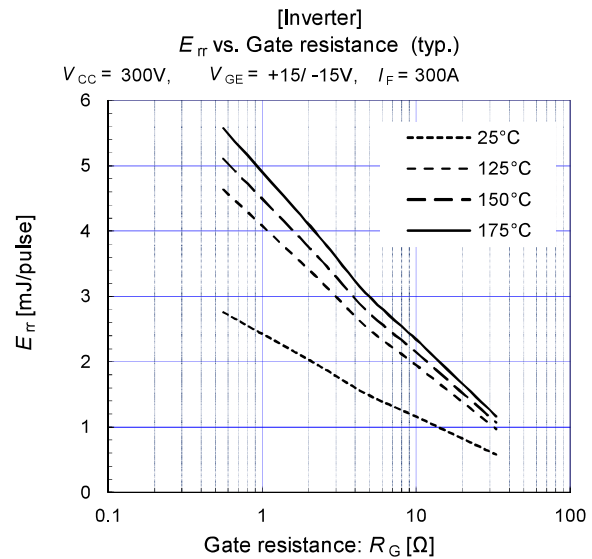
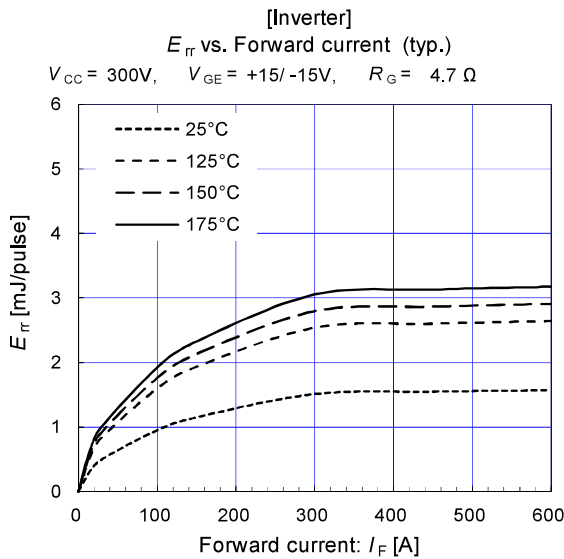
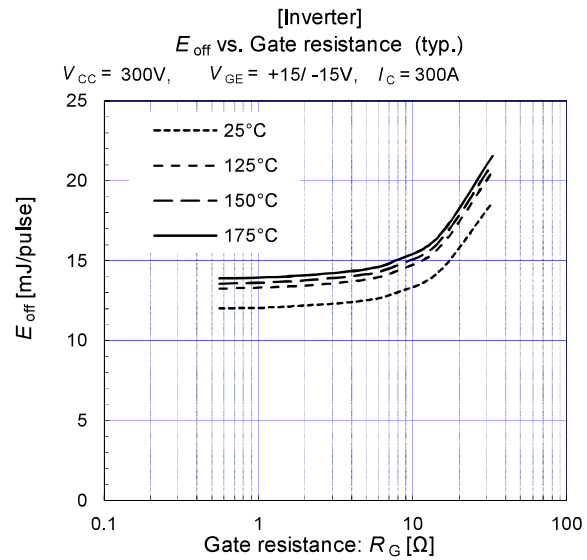
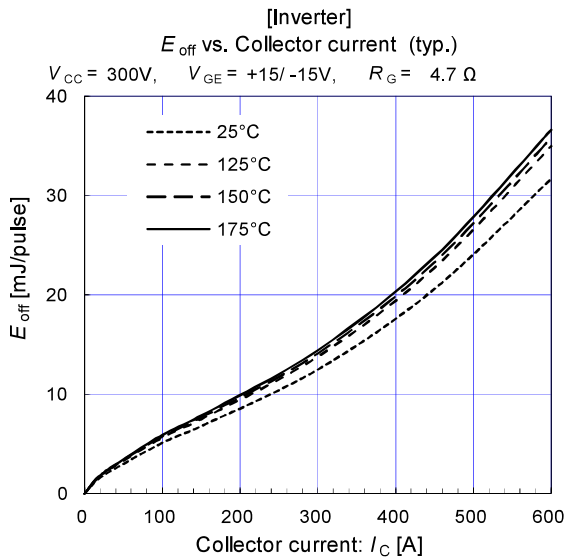
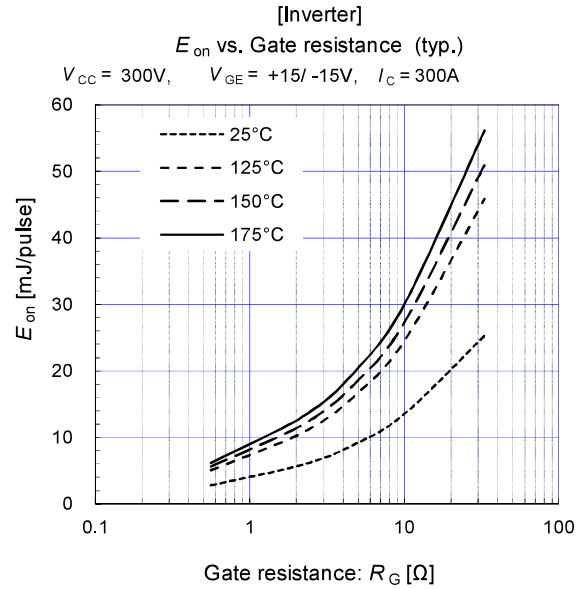
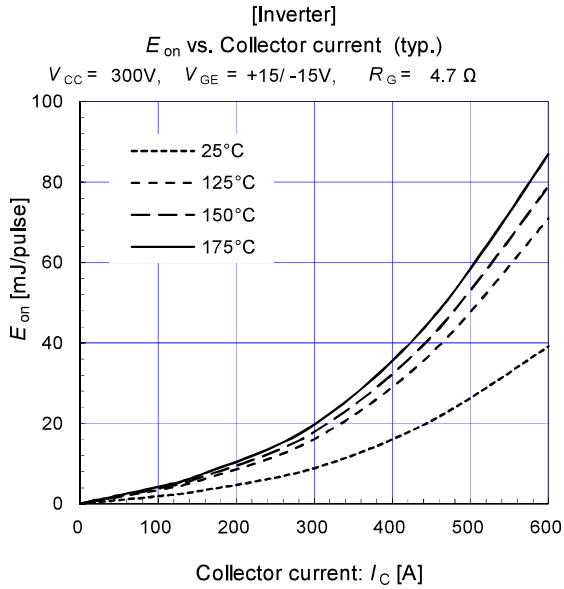

# 2MBI300XBE065-50

IGBT Modules

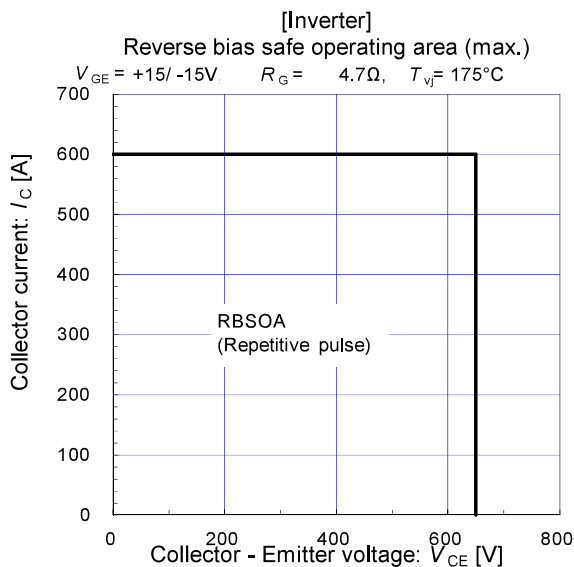
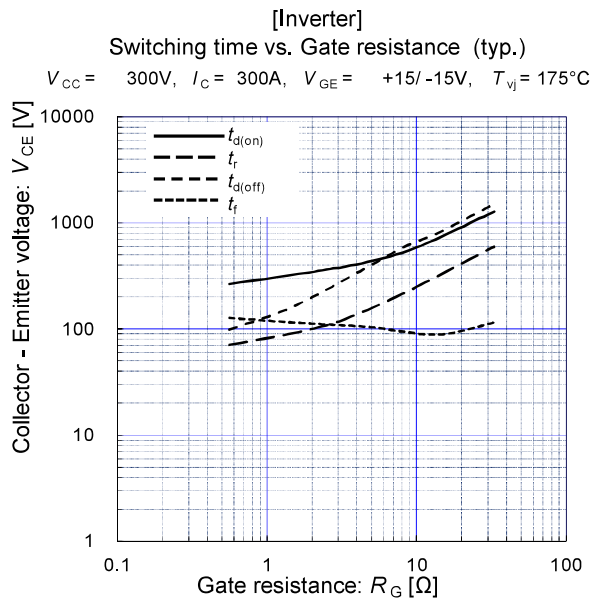
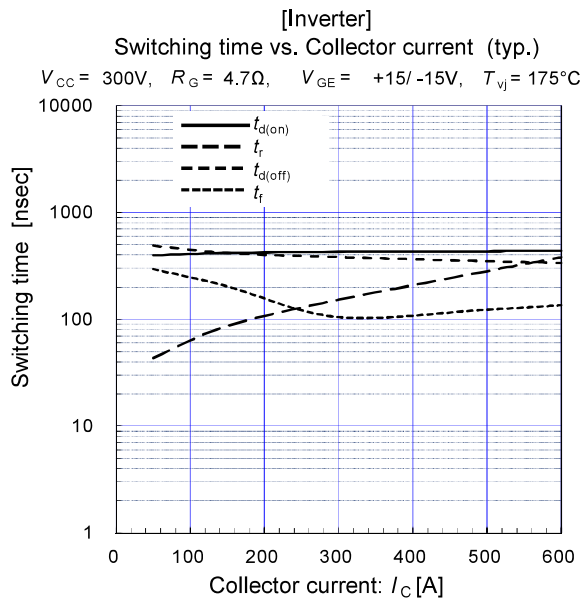
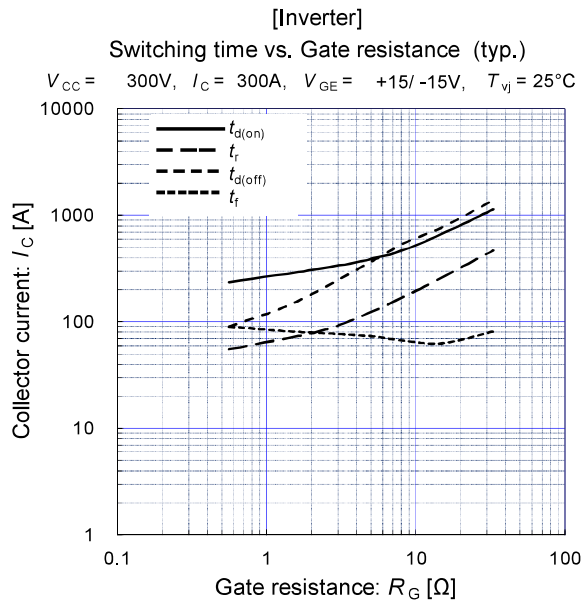
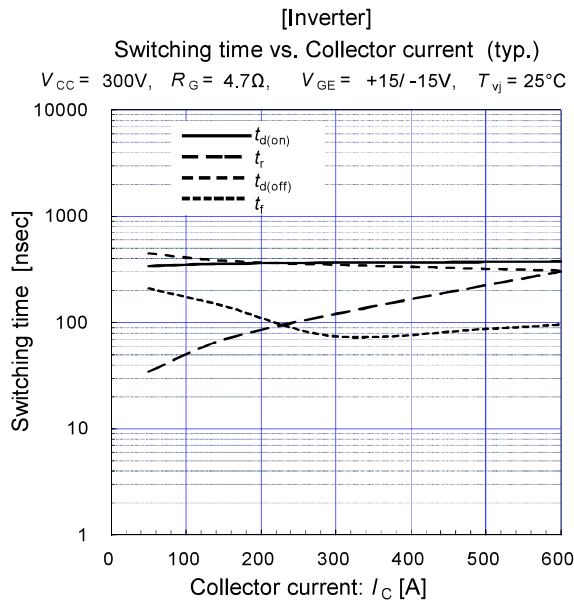

# 2MBI300XBE065-50

IGBT Modules

