

4MBI900VB-120R1-50

IGBT Modules

IGBT Power Module (V series)

1200V/900A/IGBT, $\pm 900V/900A/RB$ -IGBT, 4-in-1 package

■ **Features**

- Higher efficiency
- Optimized Advanced T-type circuit
- Reverse-Blocking IGBT as for AC Switch
- Low inductance module structure

■ **Applications**

- Inverter for motor drive
- Uninterruptible power supply
- Power conditioner for PV, Wind turbine

■ **Outline drawing**

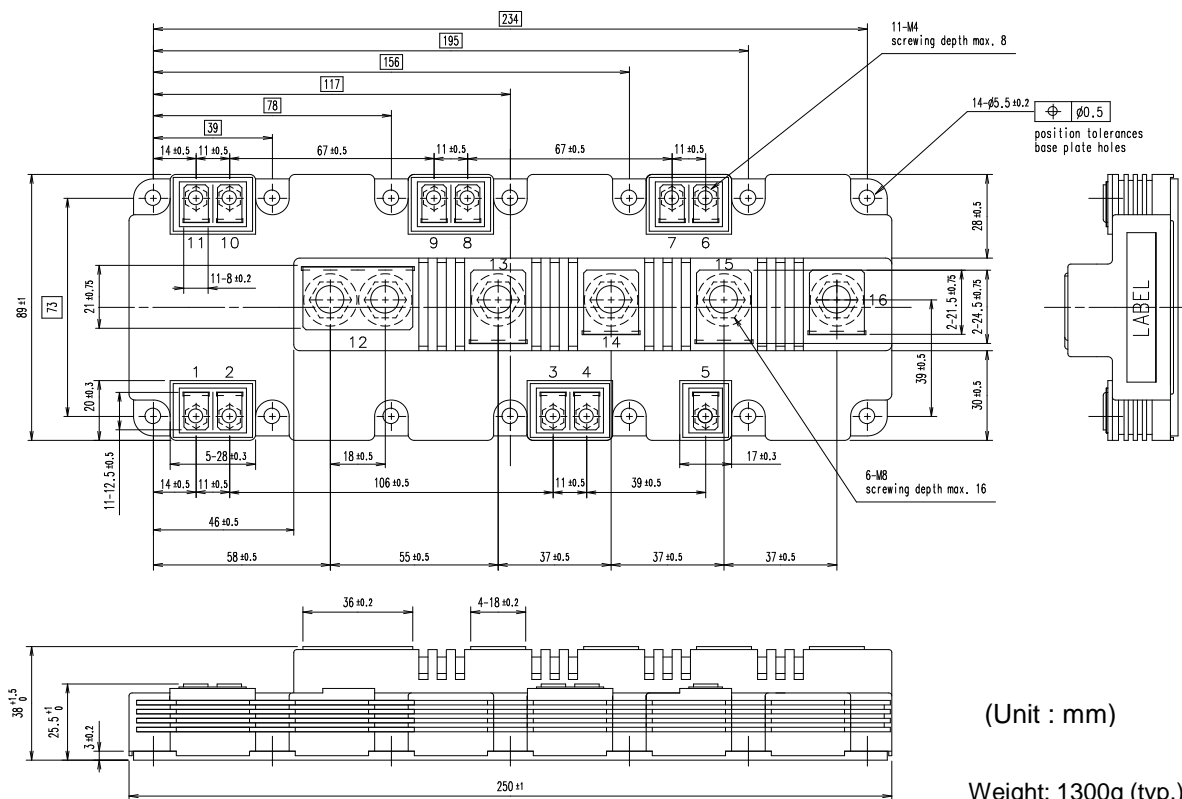
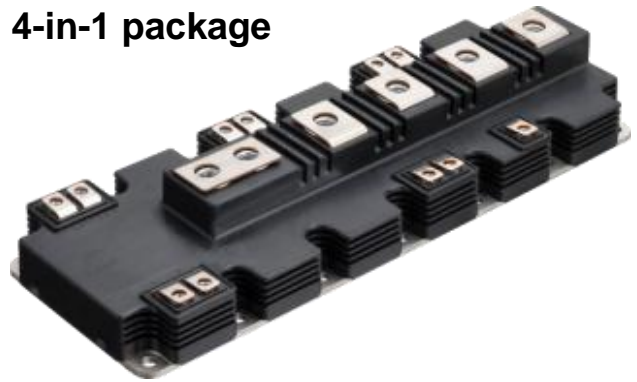

■ **Equivalent Circuit**

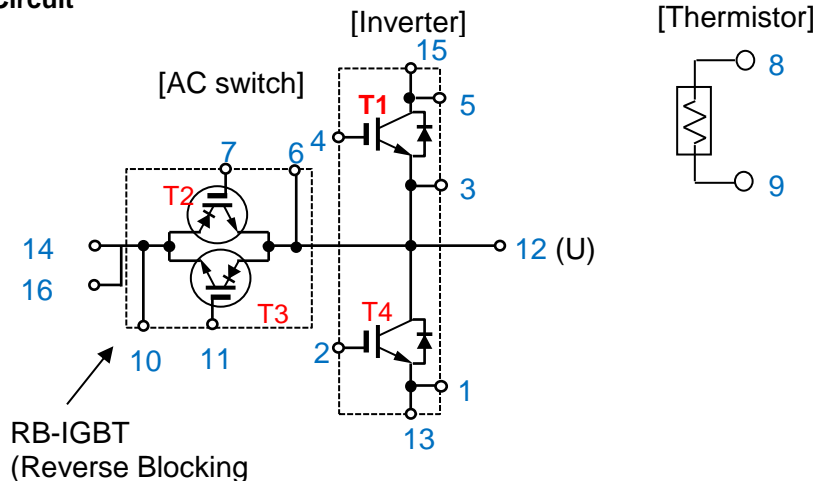

4MBI900VB-120R1-50

IGBT Modules
■ Absolute Maximum Ratings (at Tc= 25°C unless otherwise specified)

Item		Symbol	Condition	Maximum Rating	Unit	
Inverter	Collector-Emitter voltage	V_{CES}		1200	A	
	Gate-Emitter voltage	V_{GES}		±20	V	
	Collector current	IGBT	I_C	Continuous	$T_c=25^\circ\text{C}$ 1200 $T_c=100^\circ\text{C}$ 900	A
			I_C pulse	1ms	1800	
		FWD	$-I_C$		900	
			$-I_C$ pulse		1800	
	Collector power dissipation	P_C	1 device	3950	W	
	Junction temperature	T_j		175	°C	
	Operating temperature	T_{jop}		150		
	Collector-Emitter voltage	V_{CES}		±900		A
AC switch	Gate-Emitter voltage	V_{GES}		±20	V	
	Collector current	I_C	Continuous	$T_c=25^\circ\text{C}$ 1200 $T_c=80^\circ\text{C}$ 900	A	
			I_C pulse	1ms		1800
	Collector power dissipation	P_C	1 device	3675	W	
	Junction temperature	T_j		150	°C	
	Operating temperature	T_{jop}		125		
	Case temperature	T_c		125		
Storage temperature	T_{stg}		-40 ~ 125			
Isolation voltage	between terminal and copper base (*1)	V_{iso}	AC: 1min.	4000	VAC	
Screw torque	Mounting	-	M5	6.0	N m	
	Main terminals	-	M8	10.0		
	Sense terminals	-	M4	2.1		

(*1) All terminals should be connected together during the test.

(*2) Two thermistor terminals should be connected together, other terminals should be connected together and shorted to base plate during the test.

(*3) Recommended value : Mounting 3.0 ~ 6.0 Nm (M5)
 Recommended value : Main Terminals 8.0 ~ 10.0 Nm (M8)
 Recommended value : Sense Terminals 1.8 ~ 2.1 Nm (M4)

4MBI900VB-120R1-50

IGBT Modules

■ Electrical characteristics (at Tj= 25°C unless otherwise specified)

Item	Symbol	Condition	Characteristics			Units		
			min.	typ.	max.			
Inverter	Zero gate voltage Collector current	I_{CES}	$V_{GE} = 0V$ $V_{CE} = 1200V$	-	-	6	mA	
	Gate-Emitter leakage current	I_{GES}	$V_{CE} = 0V$ $V_{GE} = \pm 20V$	-	-	1200	nA	
	Gate-Emitter threshold voltage	$V_{GE(th)}$	$V_{CE} = 20V$ $I_C = 900mA$	6.0	6.5	7.0	V	
	Collector-Emitter saturation voltage	$V_{CE(sat)}$ (chip)	$V_{GE} = 15V$ $I_C = 900A$	$T_j = 25^\circ C$	-	1.85	2.35	V
				$T_j = 125^\circ C$	-	2.20	-	
		$V_{CE(sat)}$ (terminal)	$V_{GE} = 15V$ $I_C = 900A$	$T_j = 150^\circ C$	-	2.25	-	
				$T_j = 25^\circ C$	-	1.95	2.45	
	Internal gate	$R_{G(int)}$	-	-	-	0.80	-	Ω
				-	-	0.80	-	Ω
	Input capacitance	C_{ies}	$V_{CE} = 10V, V_{GE} = 0V, f = 1MHz$	-	75.5	-	nF	
	Turn-on time	t_{on}	Switching mode: A $V_{CC} = 500V$ $I_C = 900A$	t_r	-	0.60	-	μs
				$t_{r(i)}$	-	0.40	-	
				$t_{r(f)}$	-	0.15	-	
	Turn-off time	t_{off}	$V_{GE} = \pm 15V$ $R_G = +3.3/-0.56\Omega$	$t_{r(i)}$	-	0.90	-	μs
$t_{r(f)}$				-	0.08	-		
Forward on voltage	V_F (chip)	$I_F = 900A$	$T_j = 25^\circ C$	-	1.70	2.20	V	
			$T_j = 125^\circ C$	-	1.85	-		
	V_F (terminal)	$I_F = 900A$	$T_j = 150^\circ C$	-	1.80	-		
			$T_j = 25^\circ C$	-	1.85	2.35		
Reverse recovery time	t_{rr}	Switching mode: B $V_{CC} = 500V, I_F = 900A$ $V_{GE} = \pm 15V, R_G = +1.8/-12\Omega$	-	0.20	-	μs		
			-	0.20	-	μs		
AC-switch	Zero gate voltage Collector current	I_{CES}	$V_{GE} = 0V$ $V_{CE} = 900V$	-	-	12	mA	
	Gate-Emitter leakage current	I_{GES}	$V_{CE} = 0V$ $V_{GE} = \pm 20V$	-	-	2400	nA	
	Gate-Emitter threshold voltage	$V_{GE(th)}$	$V_{CE} = 20V$ $I_C = 900mA$	5.6	6.6	7.6	V	
	Collector-Emitter saturation voltage	$V_{CE(sat)}$ (chip)	$V_{GE} = 15V$ $I_C = 900A$	$T_j = 25^\circ C$	-	2.30	2.9	V
				$T_j = 125^\circ C$	-	2.70	-	
	$V_{CE(sat)}$ (terminal)	$V_{GE} = 15V$ $I_C = 900A$	$T_j = 25^\circ C$	-	2.40	3.00		
			$T_j = 125^\circ C$	-	2.80	-		
	Internal gate	$R_{G(int)}$	-	-	2.60	-	Ω	
	Input capacitance	C_{ies}	$V_{CE} = 10V, V_{GE} = 0V, f = 1MHz$	-	53.0	-	nF	
	Turn-on time	t_{on}	Switching mode: B $V_{CC} = 500V$ $I_C = 900A$	t_r	-	0.60	-	μs
				$t_{r(i)}$	-	0.25	-	
				$t_{r(f)}$	-	0.15	-	
	Turn-off time	t_{off}	$V_{GE} = \pm 15V$ $R_G = +1.8/-12\Omega$	$t_{r(i)}$	-	1.85	-	μs
				$t_{r(f)}$	-	0.15	-	
Reverse recovery time	t_{rr}	Switching mode: A $V_{CC} = 500V, I_F = 900A$ $V_{GE} = \pm 15V, R_G = +3.3/-0.56\Omega$	-	0.20	-	μs		
Thermistor	Resistance	R	$T = 25^\circ C$	-	5000	-	Ω	
	$T = 100^\circ C$	465	495	520				
B Value	B	$T = 25/50^\circ C$	3305	3375	3450	K		

(*1) Please refer to section 8, there is definition of A mode and B mode.

■ Thermal resistance characteristics

Item	Symbol	Condition	Characteristics			Units
			min.	typ.	max.	
Thermal resistance (1device)	$R_{th(j-c)}$	T1, T4 IGBT	-	-	0.038	$^\circ C/W$
		T1, T4 FWD	-	-	0.054	
		T2, T3 RB-IGBT	-	-	0.034	
Contact thermal resistance	$R_{th(c-f)}$	T1, T4	-	0.0083	-	$^\circ C/W$
		T2, T3 with thermal compound	-	0.0042	-	

(*2) This is the value which is defined mounting on the additional cooling fin with thermal compound.

4MBI900VB-120R1-50

IGBT Modules

■ Definitions of switching time

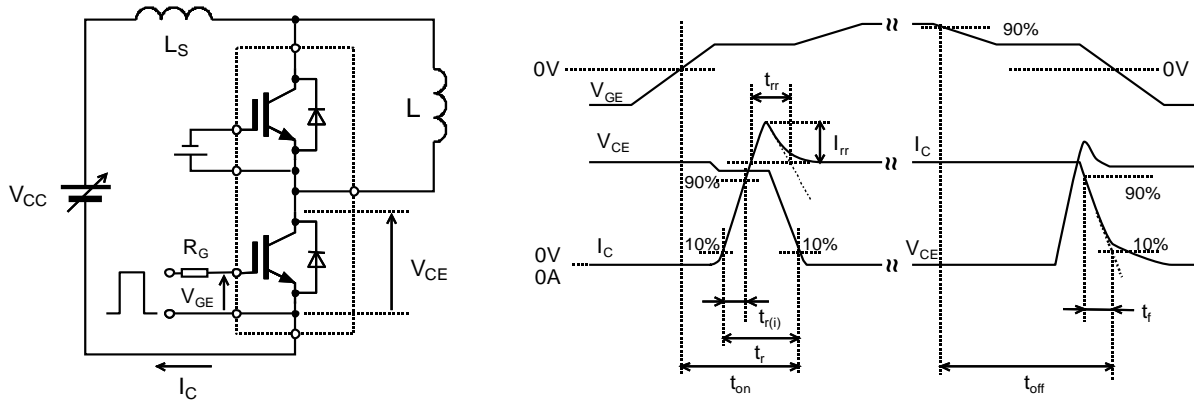

■ Definitions of switching mode

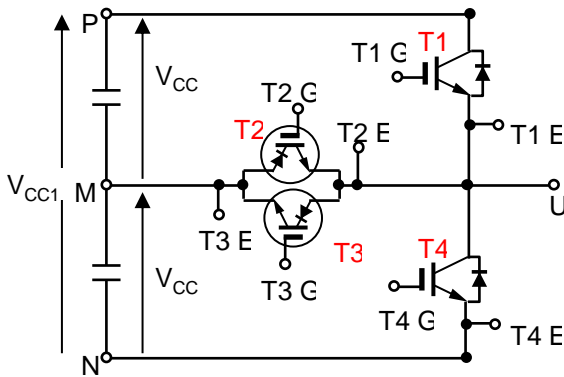

SW mode	Load L	T1	T2	T3	T4
A	M-U	SW	OFF	OFF	ON
	M-U	OFF	SW	ON	OFF
B	P-U	OFF	OFF	SW	ON
	U-N	OFF	OFF	ON	SW

SW: Connect to drive circuit and input gate signal

ON: Bias voltage of gate +15V

OFF: Reverse bias voltage of gate -15V

$V_{cc} = V_{cc1}/2$

4MBI900VB-120R1-50

IGBT Modules

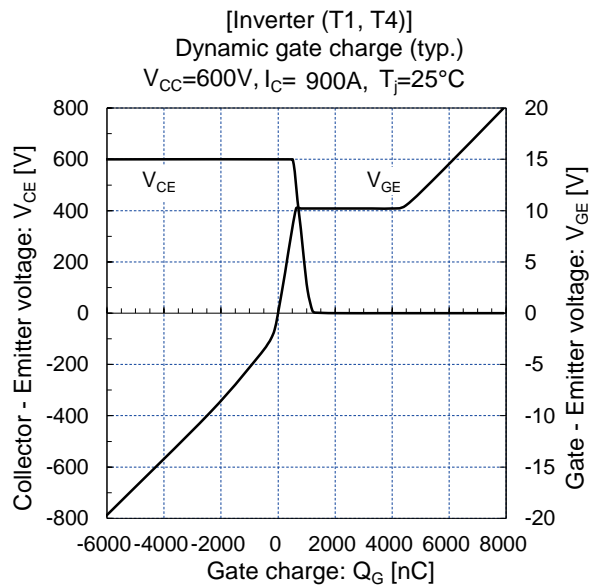
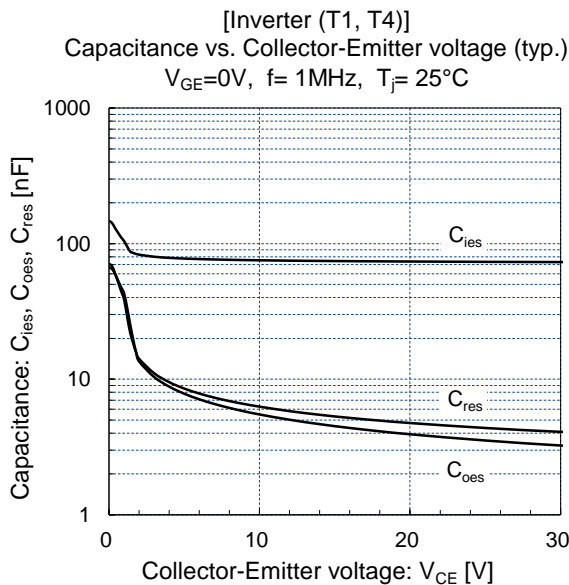
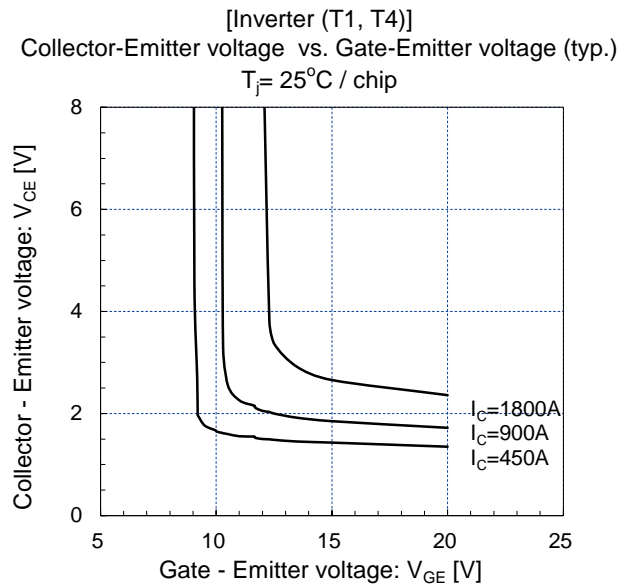
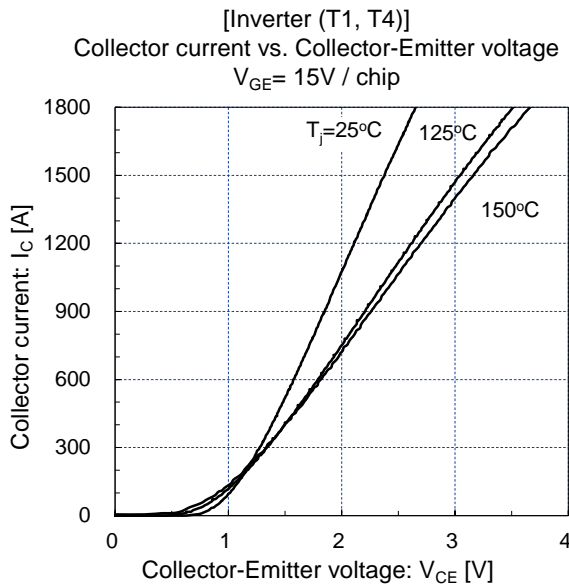
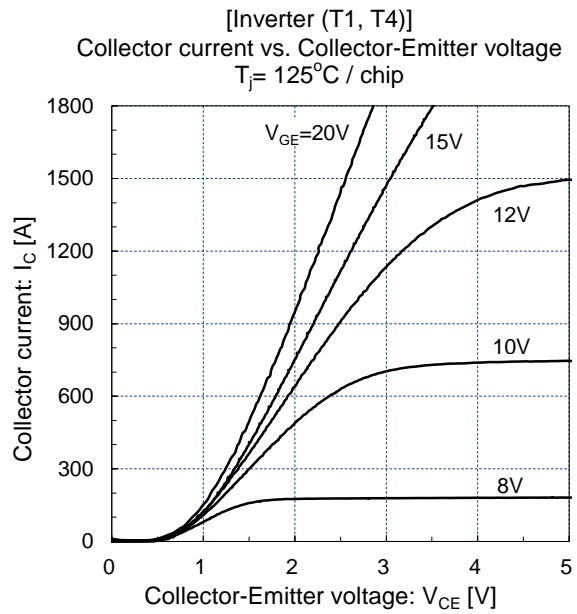
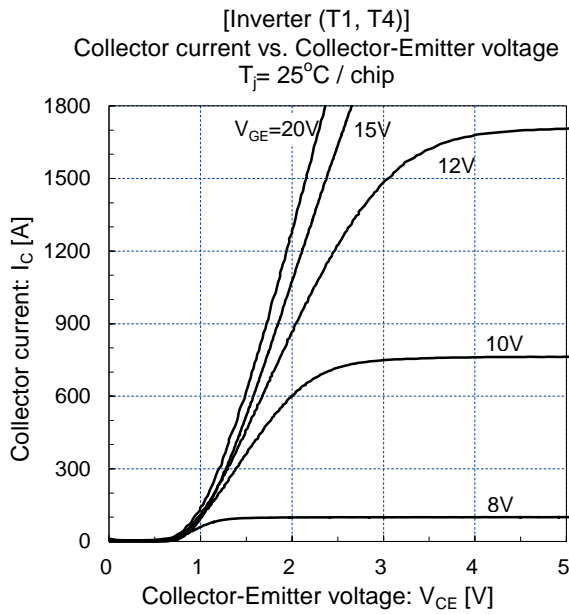

4MBI900VB-120R1-50

IGBT Modules

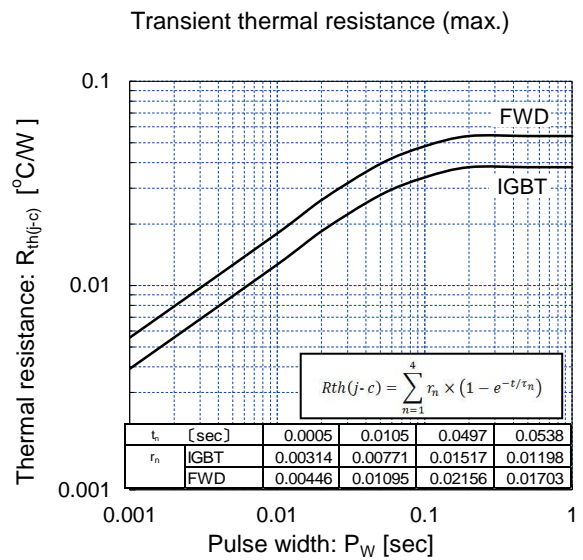
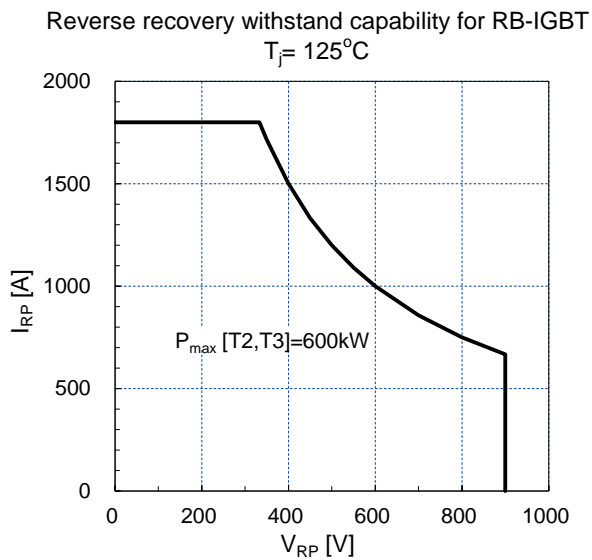
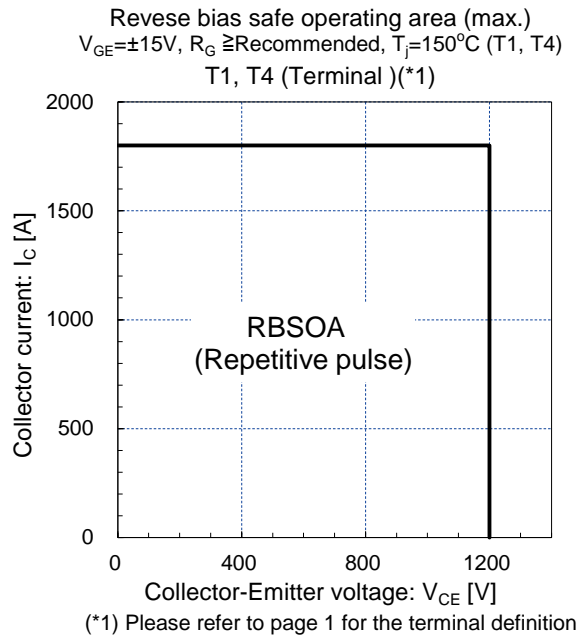
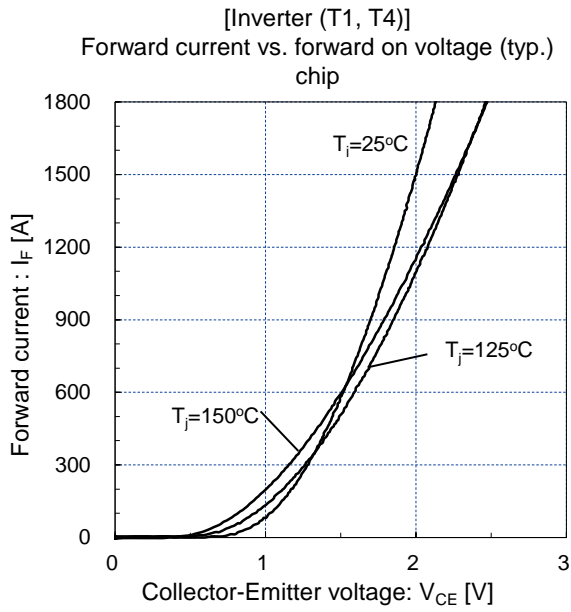

4MBI900VB-120R1-50

IGBT Modules

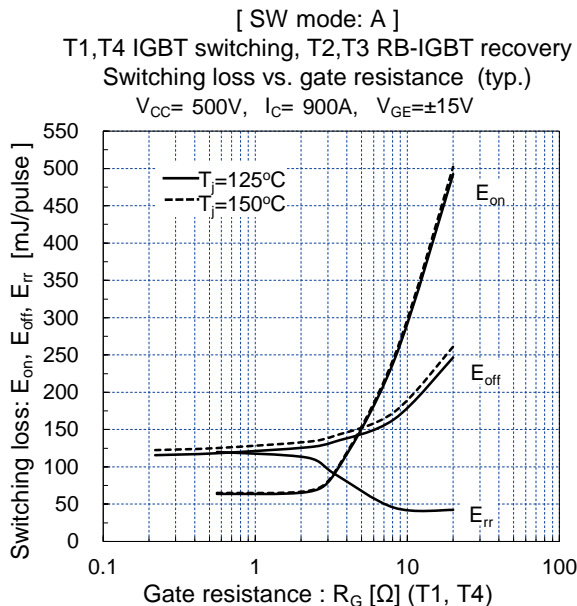
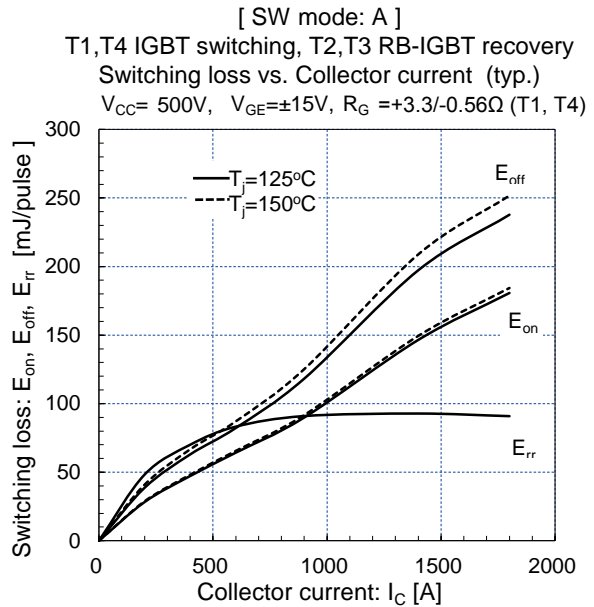
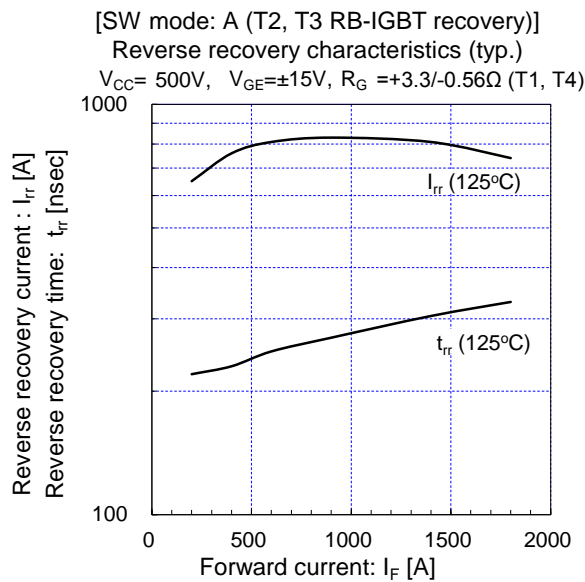
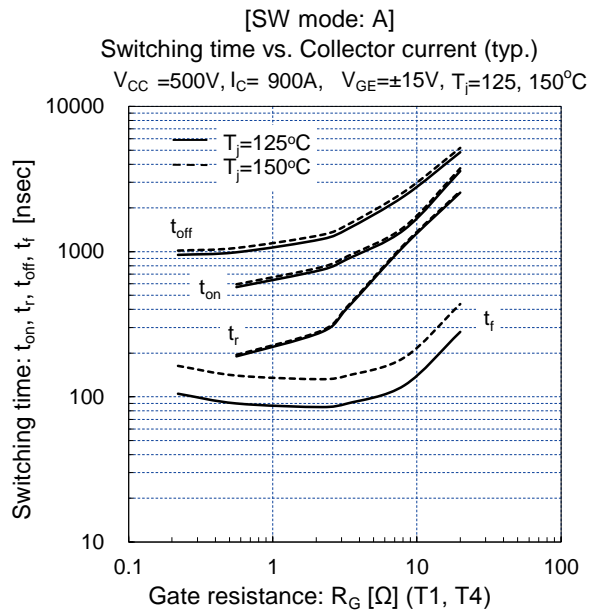
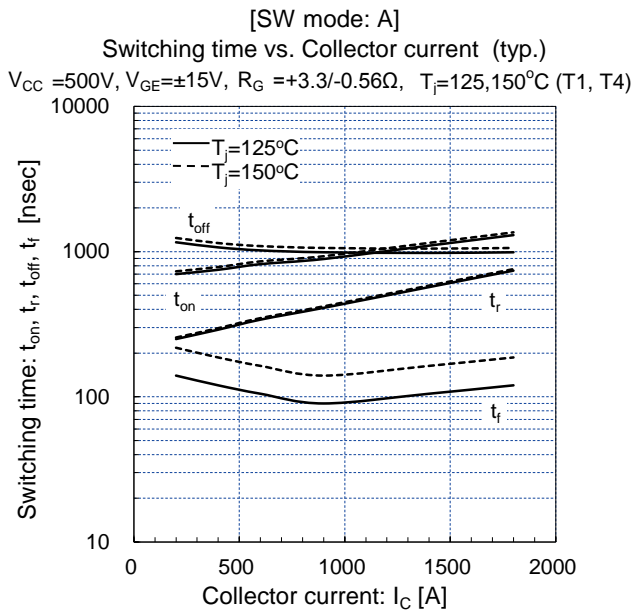

4MBI900VB-120R1-50

IGBT Modules

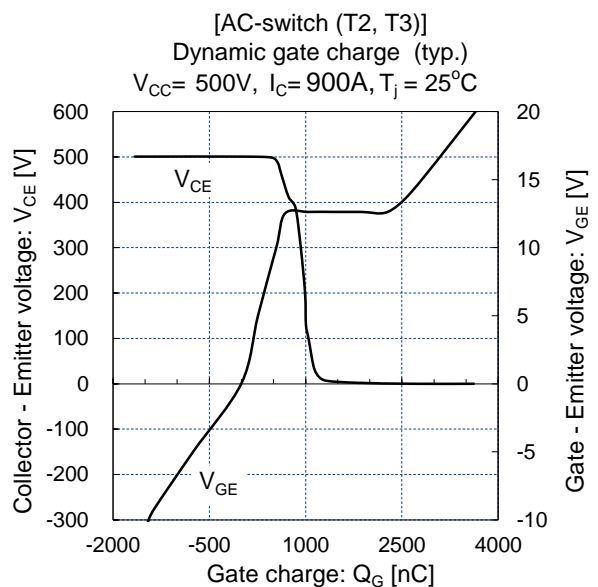
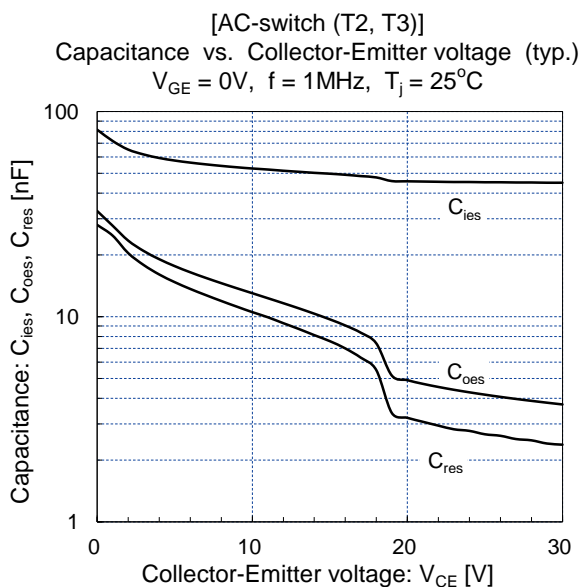
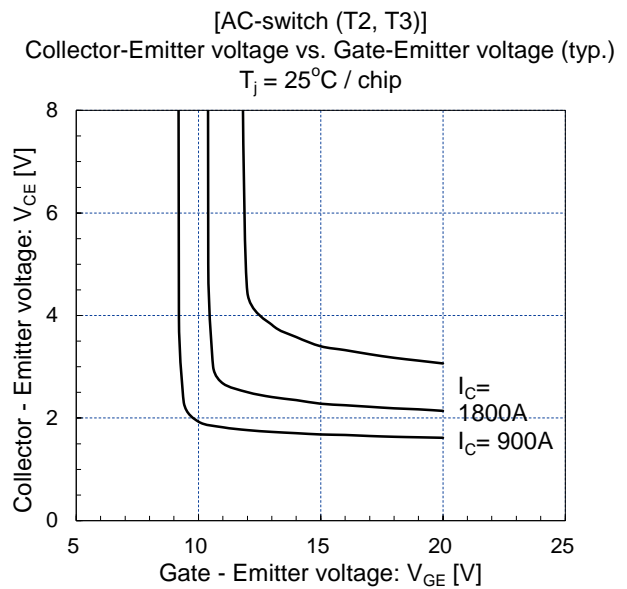
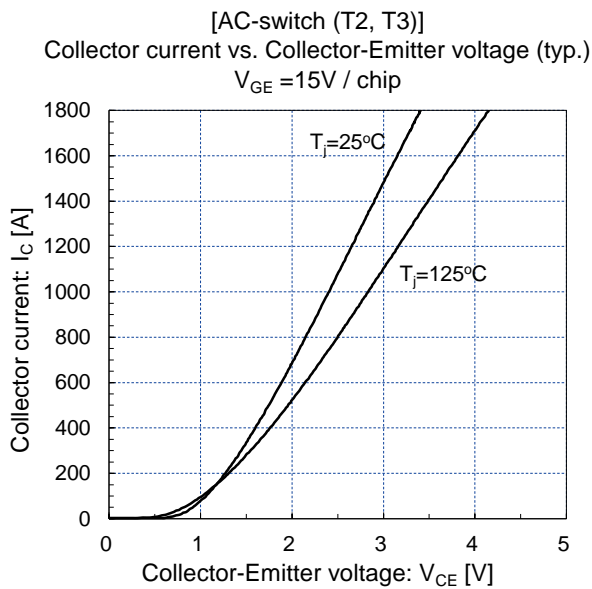
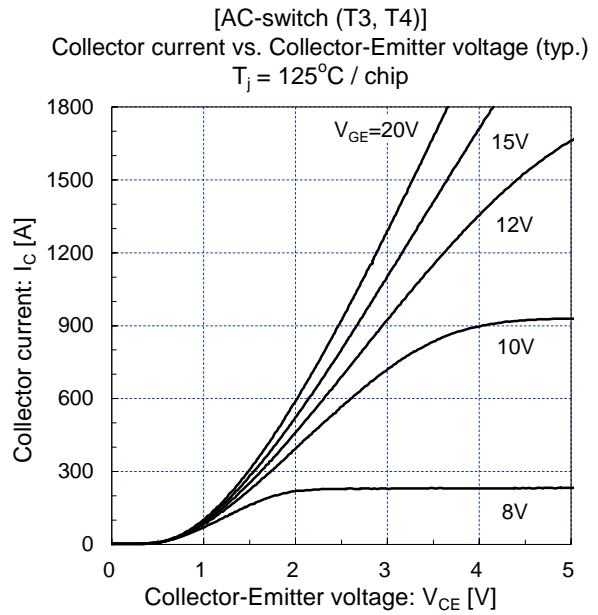
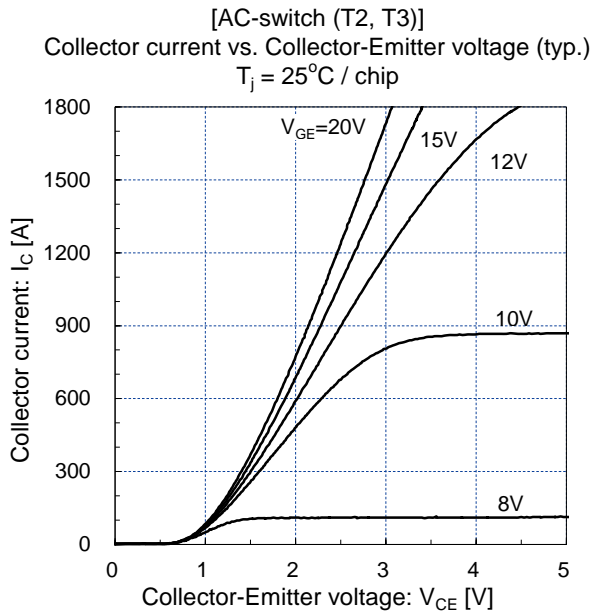

4MBI900VB-120R1-50

IGBT Modules

Reverse bias safe operating area (max.)
 $V_{GE} = \pm 15V$, $R_G \geq \text{Recommended}$, $T_J = 125^\circ C$ (T2, T3)
 T2, T3 (Terminal) (*1)

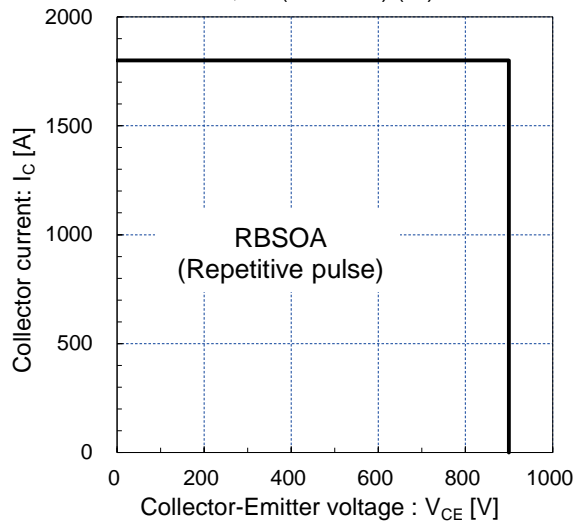

(*1) Please refer to page 1 for the terminal definition

Reverse recovery withstand capability for FWD
 $T_J = 150^\circ C$

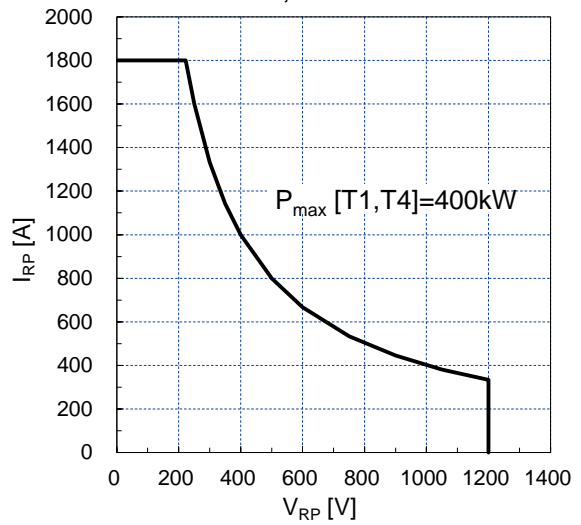

Transient thermal resistance (max.)

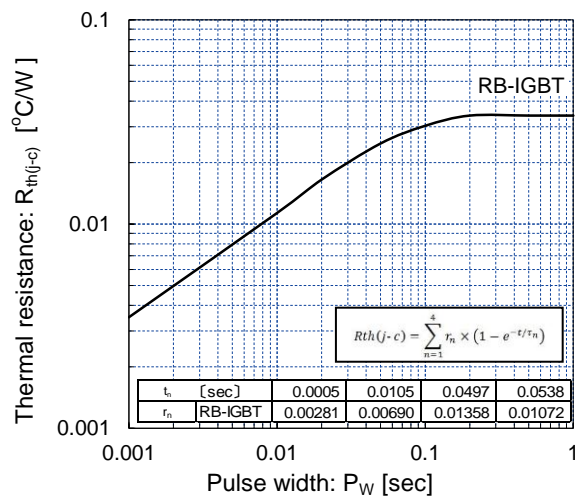

4MBI900VB-120R1-50

IGBT Modules

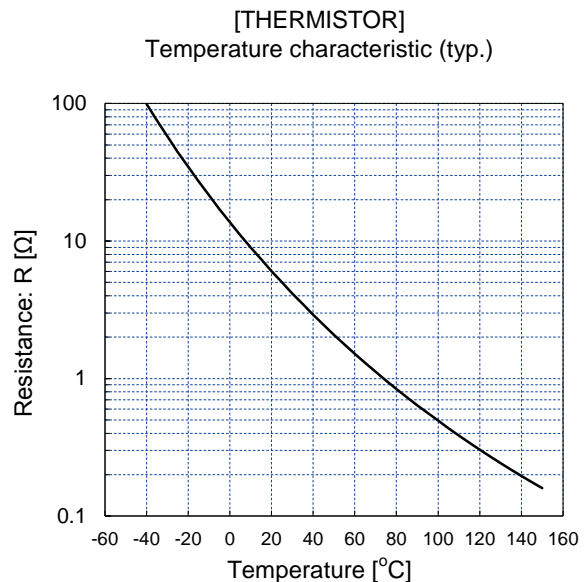
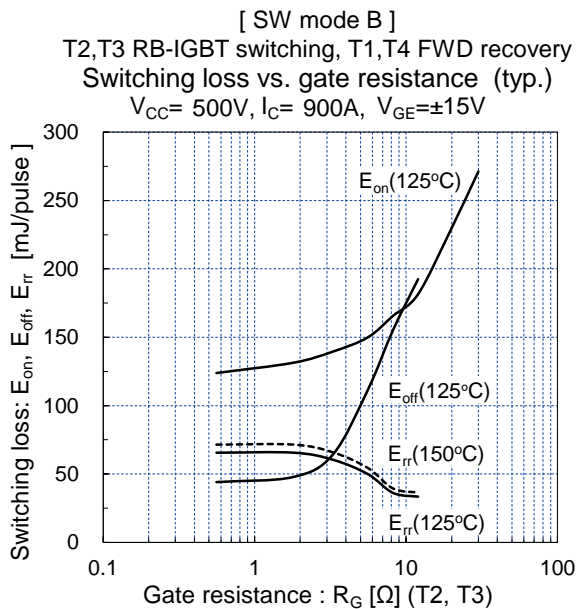
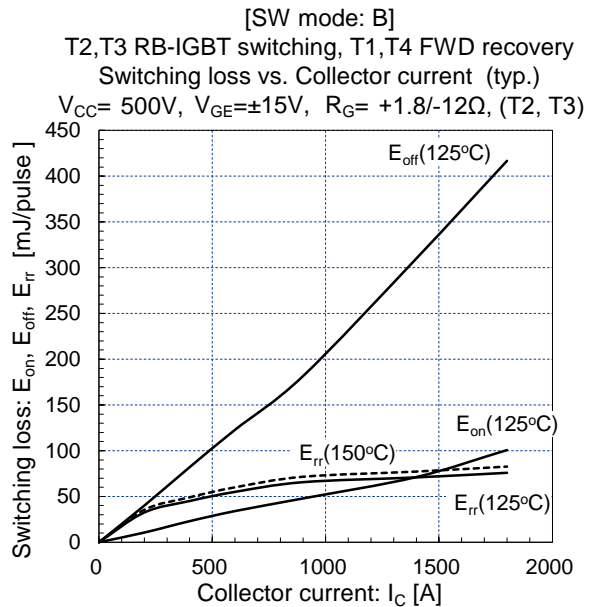
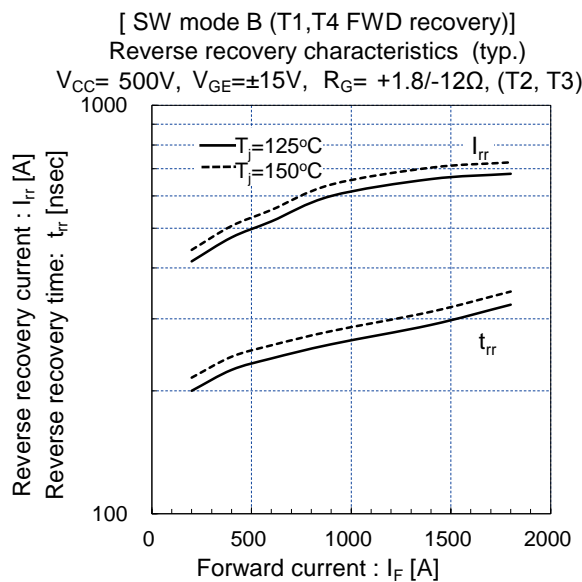
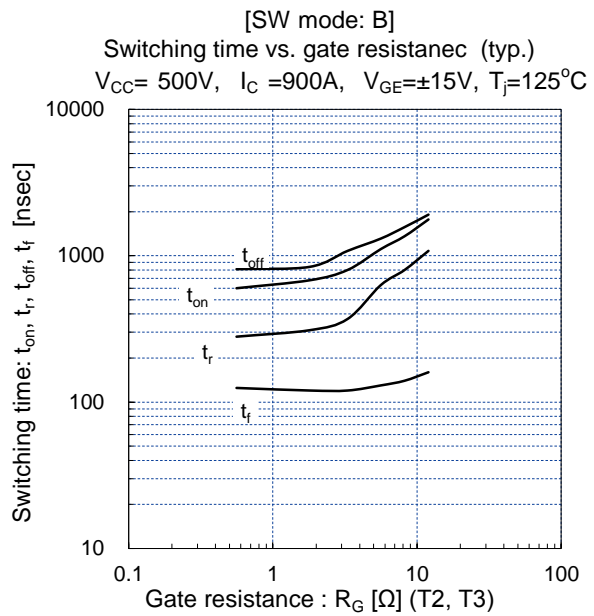
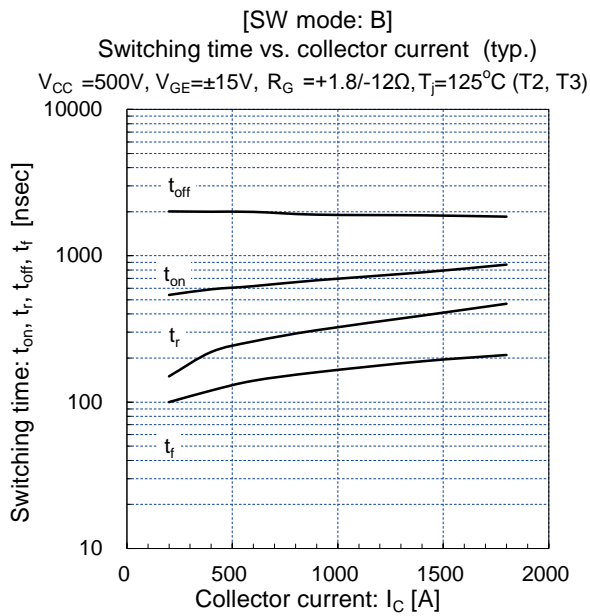

Warnings

1. This Catalog contains the product specifications, characteristics, data, materials, and structures as of 12/2014. The contents are subject to change without notice for specification changes or other reasons. When using a product listed in this Catalog, be sure to obtain the latest specifications.
2. All applications described in this Catalog exemplify the use of Fuji's products for your reference only. No right or license, either express or implied, under any patent, copyright, trade secret or other intellectual property right owned by Fuji Electric Co., Ltd. is (or shall be deemed) granted. Fuji Electric Co., Ltd. makes no representation or warranty, whether express or implied, relating to the infringement or alleged infringement of other's intellectual property rights which may arise from the use of the applications described herein.
3. Although Fuji Electric Co., Ltd. is enhancing product quality and reliability, a small percentage of semiconductor products may become faulty. When using Fuji Electric semiconductor products in your equipment, you are requested to take adequate safety measures to prevent the equipment from causing a physical injury, fire, or other problem if any of the products become faulty. It is recommended to make your design fail-safe, flame retardant, and free of malfunction.
4. The products introduced in this Catalog are intended for use in the following electronic and electrical equipment which has normal reliability requirements.
 - Computers · OA equipment · Communications equipment (terminal devices) · Measurement equipment
 - Machine tools · Audiovisual equipment · Electrical home appliances · Personal equipment · Industrial robots etc.
5. If you need to use a product in this Catalog for equipment requiring higher reliability than normal, such as for the equipment listed below, it is imperative to contact Fuji Electric Co., Ltd. to obtain prior approval. When using these products for such equipment, take adequate measures such as a backup system to prevent the equipment from malfunctioning even if a Fuji's product incorporated in the equipment becomes faulty.
 - Transportation equipment (mounted on cars and ships) · Trunk communications equipment
 - Traffic-signal control equipment · Gas leakage detectors with an auto-shut-off feature
 - Emergency equipment for responding to disasters and anti-burglary devices · Safety devices · Medical equipment
6. Do not use products in this Catalog for the equipment requiring strict reliability such as the following and equivalents to strategic equipment (without limitation).
 - Space equipment · Aeronautic equipment · Nuclear control equipment · Submarine repeater equipment
7. Copyright (c)1996-2014 by Fuji Electric Co., Ltd. All rights reserved.
No part of this Catalog may be reproduced in any form or by any means without the express permission of Fuji Electric Co., Ltd.
8. If you have any question about any portion in this Catalog, ask Fuji Electric Co., Ltd. or its sales agents before using the product. Neither Fuji Electric Co., Ltd. nor its agents shall be liable for any injury caused by any use of the products not in accordance with instructions set forth herein.