

## IGBT FOUR PAK MODULE

### Features

- Square RBSOA
- HEXFRED low  $Q_{rr}$ , low Switching Energy
- Positive  $V_{CE(on)}$  Temperature Coefficient
- Copper Baseplate
- Low Stray Inductance Design



ECONO2 4PAK

$$V_{CES} = 1200V$$

$$I_C = 75A @ T_C = 67^\circ C$$

$$V_{CE(on)} \text{ typ.} = 3.4V$$

### Benefits

- Benchmark Efficiency for SMPS appreciation in particular HF welding
- Rugged Transient Performance
- Low EMI, Requires Less Snubbing
- Direct Mounting to Heatsink space saving
- PCB Solderable Terminals
- Low Junction to Case Thermal Resistance

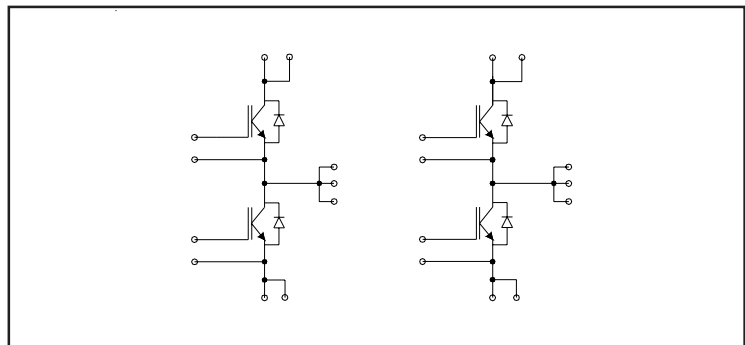

### Absolute Maximum Ratings

	Parameter	Max.	Units
$V_{CES}$	Collector-to-Emitter Voltage	1200	V
$I_C @ T_C=25^\circ C$	Continuous Collector Current	100	A
$I_C @ T_C=80^\circ C$	Continuous Collector Current	67	
$I_{CM}$	Pulsed Collector Current (Ref. Fig. C.T.5)	200	
$I_{LM}$	Clamped Inductive Load Current	200	
$I_F @ T_C=25^\circ C$	Diode Continuous Forward Current	40	
$I_F @ T_C=80^\circ C$	Diode Continuous Forward Current	25	
$I_{FM}$	Diode Maximum Forward Current	150	
$V_{GE}$	Gate-to-Emitter Voltage	$\pm 20$	V
$P_D @ T_C=25^\circ C$	Maximum Power Dissipation (IGBT)	480	W
$P_D @ T_C=80^\circ C$	Maximum Power Dissipation (IGBT)	270	
$T_J$	Maximum Operating Junction Temperature	150	$^\circ C$
$T_{STG}$	Storage Temperature Range	-40 to +125	
$V_{ISOL}$	Isolation Voltage	AC 2500 (MIN)	V

### Thermal and Mechanical Characteristics

	Parameter	Min	Typical	Maximum	Units
$R_{\theta JC}$ (IGBT)	Junction-to-Case IGBT	-	-	0.26	$^\circ C/W$
$R_{\theta JC}$ (Diode)	Junction-to-Case Diode	-	-	1.00	
$R_{\theta CS}$ (Module)	Case-to-Sink, flat, greased surface	-	0.05	-	
	Mounting Torque (M5)	2.7	-	3.3	N*m
	Weight	-	170	-	g

## Electrical Characteristics @ T<sub>J</sub> = 25°C (unless otherwise specified)

	Parameter	Min.	Typ.	Max.	Units	Conditions
BV <sub>(CES)</sub>	Collector-to-Emitter Breakdown Voltage	1200	-	-	V	V <sub>GE</sub> = 0 IC = 500μA
V <sub>CE(ON)</sub>	Collector-to-Emitter Voltage	-	3.4	4.0	V	I <sub>C</sub> = 75A V <sub>GE</sub> = 15V
		-	3.8	4.5		I <sub>C</sub> = 100A V <sub>GE</sub> = 15V
		-	4.0	4.5		I <sub>C</sub> = 75A V <sub>GE</sub> = 15V T <sub>J</sub> = 125°C
		-	4.53	5.1		I <sub>C</sub> = 100A V <sub>GE</sub> = 15V T <sub>J</sub> = 125°C
V <sub>GE(th)</sub>	Gate Threshold Voltage	4.0	5.0	6.0		V <sub>CE</sub> = V <sub>GE</sub> IC = 250μA
ΔV <sub>GE(th)</sub> /ΔT <sub>J</sub>	Thresold Voltage temp. coefficient	-	-11	-	mV/°C	V <sub>CE</sub> = V <sub>GE</sub> IC = 1mA (25°C-125°C)
I <sub>CES</sub>	Zero Gate Voltage Collector Current	-	7	250	μA	V <sub>GE</sub> = 0 V <sub>CE</sub> = 1200V
		-	580	2000		V <sub>GE</sub> = 0 V <sub>CE</sub> = 1200V T <sub>J</sub> = 125°C
V <sub>FM</sub>	Diode Forward Voltage Drop	-	3.9	5.0	V	I <sub>F</sub> = 75A
		-	4.43	5.8		I <sub>F</sub> = 100A
		-	4.37	5.4		I <sub>F</sub> = 75A T <sub>J</sub> = 125°C
		-	5.02	6.4		I <sub>F</sub> = 100A T <sub>J</sub> = 125°C
I <sub>GES</sub>	Gate-to-Emitter Leakage Current	-	-	± 200	nA	V <sub>GE</sub> = ±20V

## Switching Characteristics @ T<sub>J</sub> = 25°C (unless otherwise specified)

	Parameter	Min.	Typ.	Max.	Units	Conditions
Q <sub>G</sub>	Total Gate Charge (turn-on)	-	630	-	nC	I <sub>C</sub> = 50A
Q <sub>GE</sub>	Gate-to-Emitter Charge (turn-on)	-	65	-		V <sub>CC</sub> = 600A
Q <sub>GC</sub>	Gate-to-Collector Charge (turn-on)	-	250	-		V <sub>GE</sub> = 15V
E <sub>ON</sub>	Turn-On Switching Loss	-	1505	-	μJ	I <sub>C</sub> = 50A V <sub>CC</sub> = 600V
E <sub>OFF</sub>	Turn-Off Switching Loss	-	2411	-		V <sub>GE</sub> = 15V R <sub>G</sub> = 4.7Ω L = 500μH
E <sub>TOT</sub>	Total Switching Loss	-	3916	-		T <sub>J</sub> = 25°C ①
E <sub>ON</sub>	Turn-On Switching Loss	-	2248	-	μJ	I <sub>C</sub> = 50A V <sub>CC</sub> = 600V
E <sub>OFF</sub>	Turn-Off Switching Loss	-	3351	-		V <sub>GE</sub> = 15V R <sub>G</sub> = 4.7Ω L = 500μH
E <sub>TOT</sub>	Total Switching Loss	-	7599	-		T <sub>J</sub> = 125°C ①
t <sub>d(on)</sub>	Turn-On delay time	-	169	-	ns	I <sub>C</sub> = 50A V <sub>CC</sub> = 600V
t <sub>r</sub>	Rise time	-	71	-		V <sub>GE</sub> = 15V R <sub>G</sub> = 4.7Ω L = 500μH
t <sub>d(off)</sub>	Turn-Off delay time	-	393	-		T <sub>J</sub> = 125°C
t <sub>f</sub>	Fall time	-	136	-		
RBSOA	Reverse Bias Safe Operating Area	FULL SQUARE				T <sub>J</sub> = 150°C I <sub>C</sub> = 150A R <sub>G</sub> = 10Ω V <sub>GE</sub> = 15V to 0
SCSOA	Short Circuit Safe Operating Area	10	-	-	μs	T <sub>J</sub> = 150°C V <sub>CC</sub> = 900V V <sub>P</sub> = 1200V R <sub>G</sub> = 10Ω V <sub>GE</sub> = 15V to 0
I <sub>rr</sub>	Diode Peak Rev. Recovery Current	-	1.45	2.5	A	T <sub>J</sub> = 25°C
		-	2.35	4.0		T <sub>J</sub> = 125°C
t <sub>rr</sub>	Diode Rev. Recovery Time	-	0.401	0.5	μs	T <sub>J</sub> = 25°C V <sub>CC</sub> = 600V I <sub>F</sub> = 75A
		-	0.655	0.8		T <sub>J</sub> = 125°C dl/dt = 10A/μs
Q <sub>rr</sub>	Total Rev. Recovery Charge	-	0.181	0.4	μC	T <sub>J</sub> = 25°C
		-	0.54	1.5		T <sub>J</sub> = 125°C

① Energy losses include "tail" and diode reverse recovery.

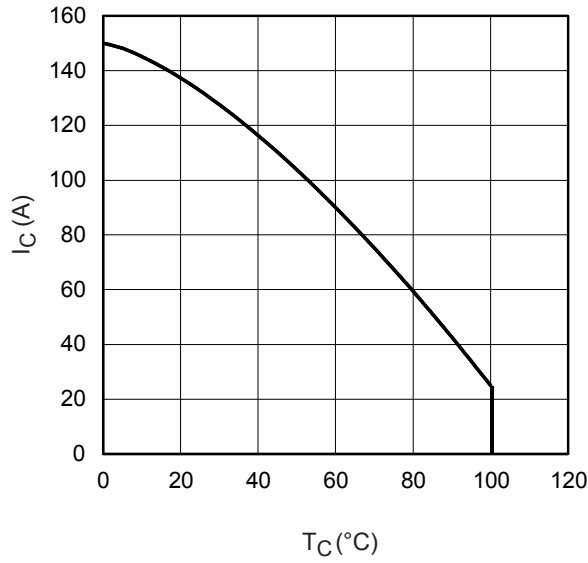

**Fig. 1** - Maximum DC Collector Current vs. Case Temperature

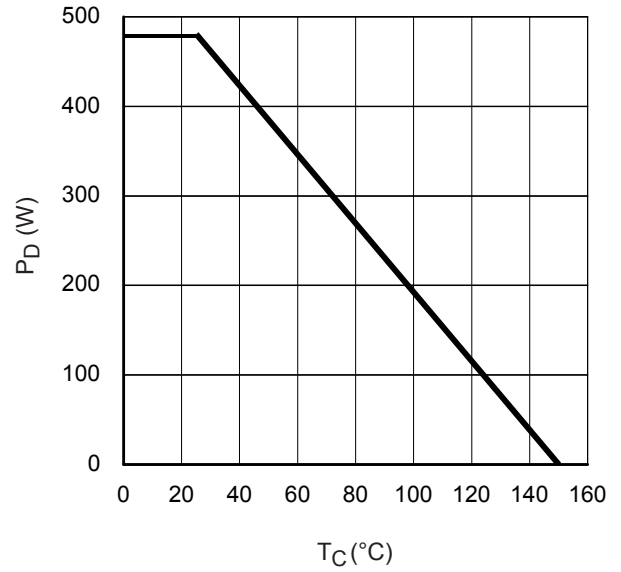

**Fig. 2** - Power Dissipation vs. Case Temperature

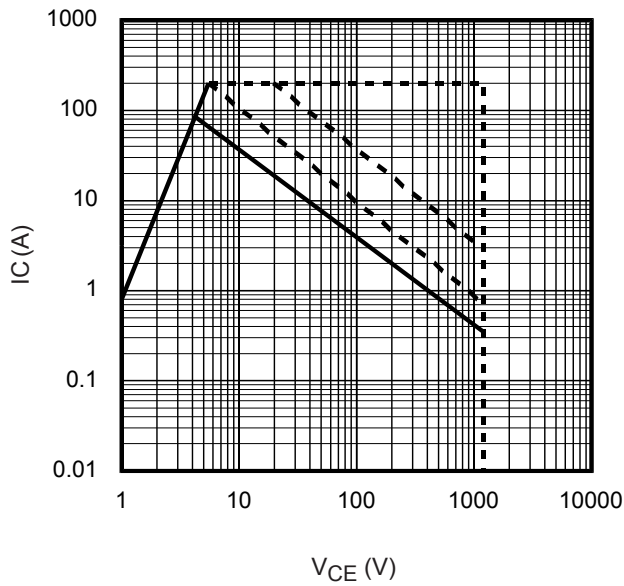

**Fig. 3** - Forward SOA  
 $T_C = 25^{\circ}C$ ;  $T_J \leq 150^{\circ}C$

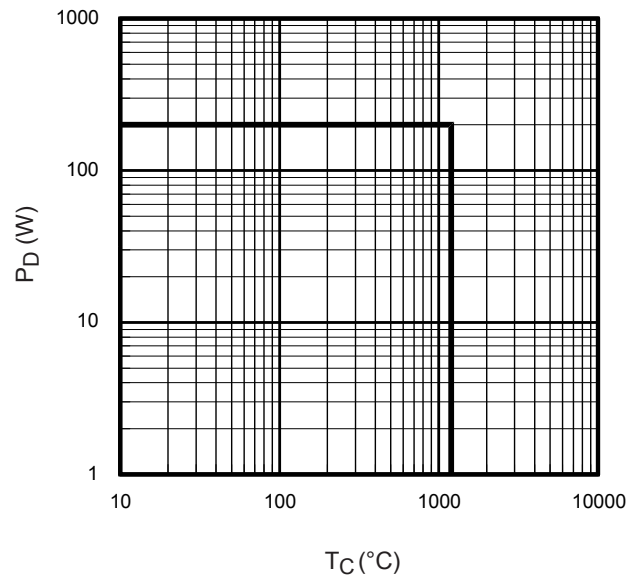
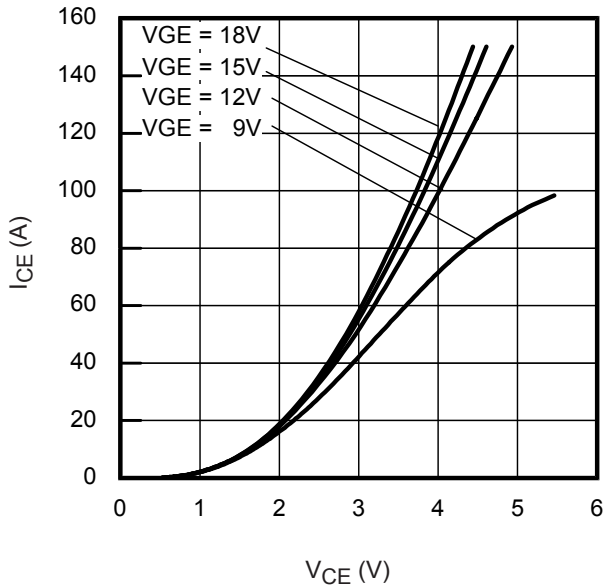

**Fig. 4** - Reverse Bias SOA  
 $T_J = 150^{\circ}C$ ;  $V_{GE} = 15V$

# GB75YF120N

Bulletin I27209 01/06

International  
**IGOR** Rectifier



**Fig. 5** - Typ. IGBT Output Characteristics  
 $T_J = 25^\circ\text{C}$ ;  $t_p = 500\mu\text{s}$

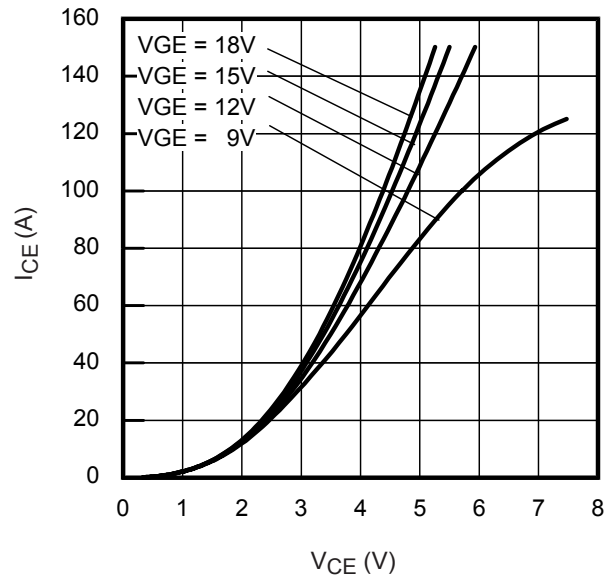

**Fig. 6** - Typ. IGBT Output Characteristics  
 $T_J = 125^\circ\text{C}$ ;  $t_p = 500\mu\text{s}$

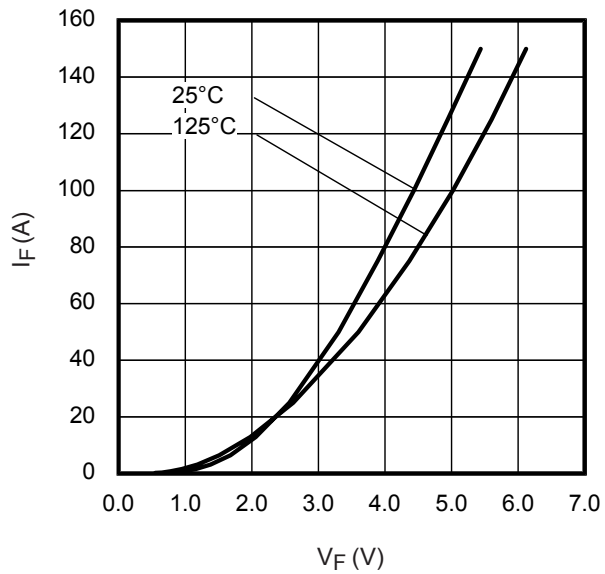

**Fig. 7** - Typ. Diode Forward Characteristics  
 $t_p = 500\mu\text{s}$

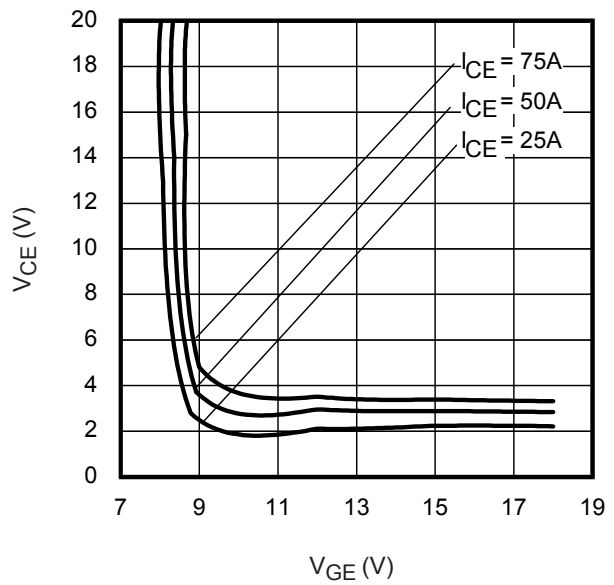

**Fig. 8** - Typical  $V_{CE}$  vs.  $V_{GE}$   
 $T_J = 25^\circ\text{C}$

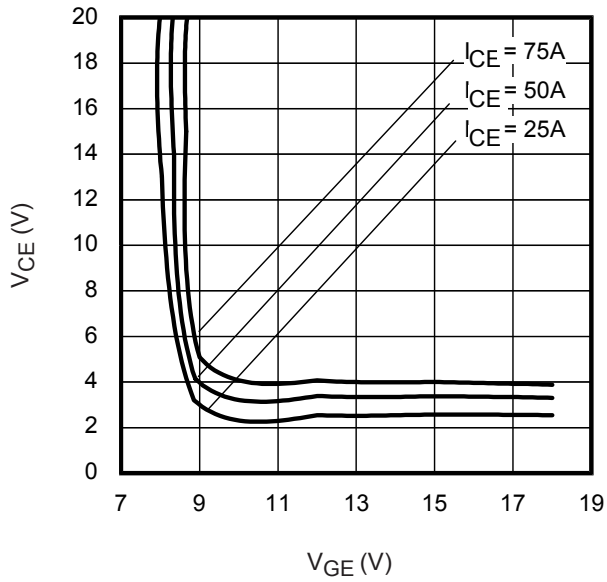

**Fig. 9** - Typical  $V_{CE}$  vs.  $V_{GE}$   
 $T_J = 125^\circ C$

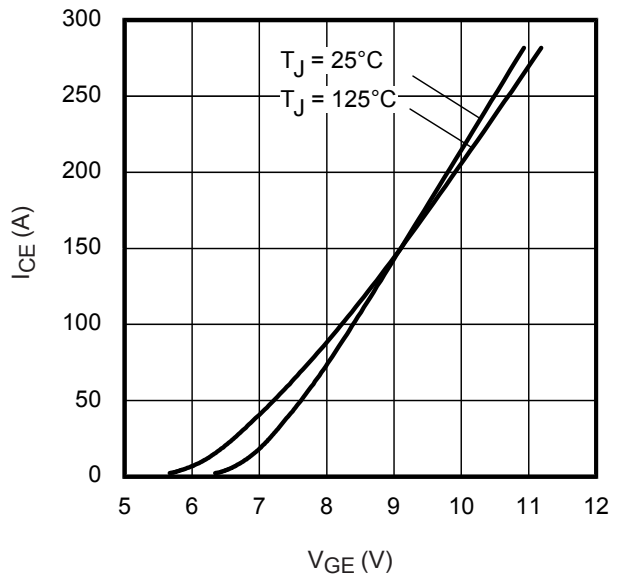

**Fig. 10** - Typ. Transfer Characteristics  
 $V_{CE} = 20V$ ;  $t_p = 500\mu s$

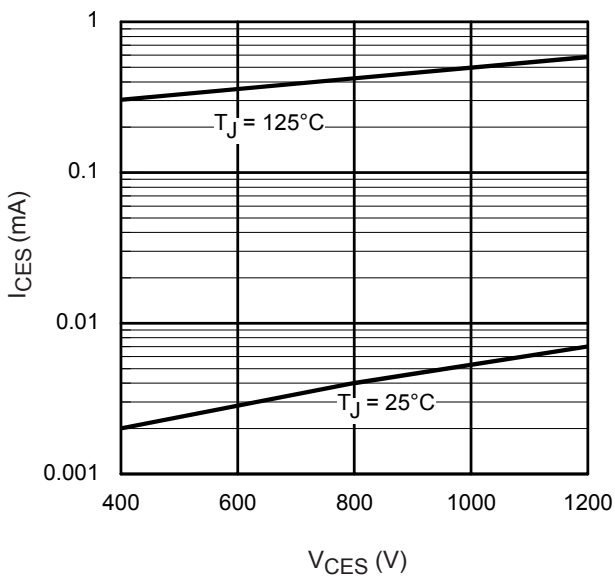

**Fig. 11** - Typ Zero Gate Voltage Collector Current

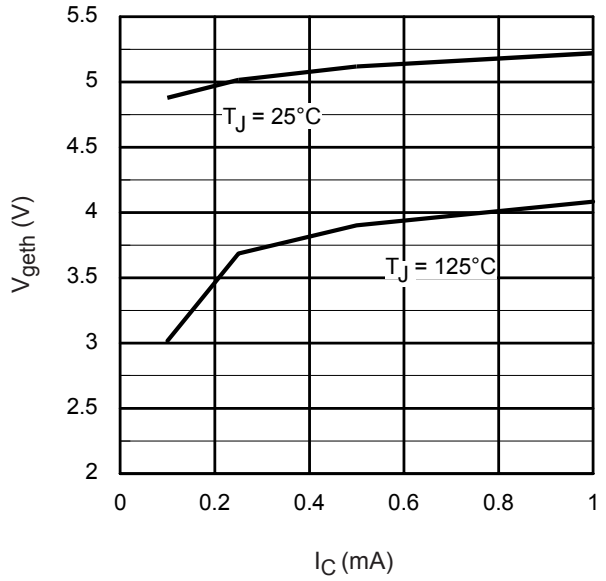

**Fig. 12** - Typ Threshold Voltage

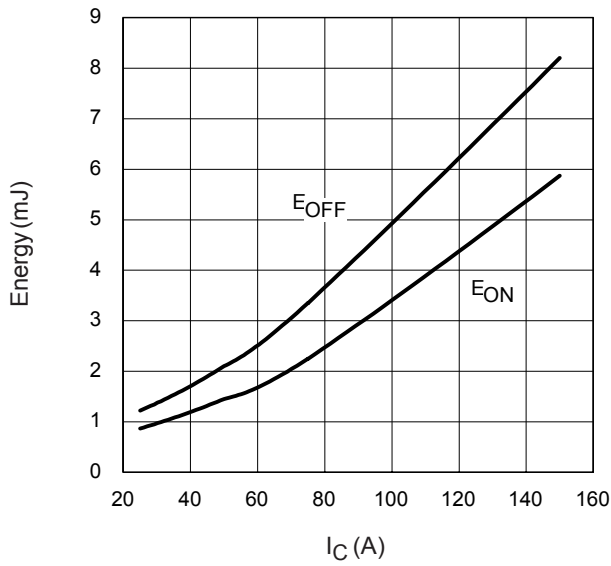

**Fig. 13** - Typ. Energy Loss vs.  $I_C$   
 $T_J = 125^\circ\text{C}$ ;  $L = 200\mu\text{H}$ ;  $V_{CE} = 600\text{V}$   
 $R_G = 5\Omega$ ;  $V_{GE} = 15\text{V}$

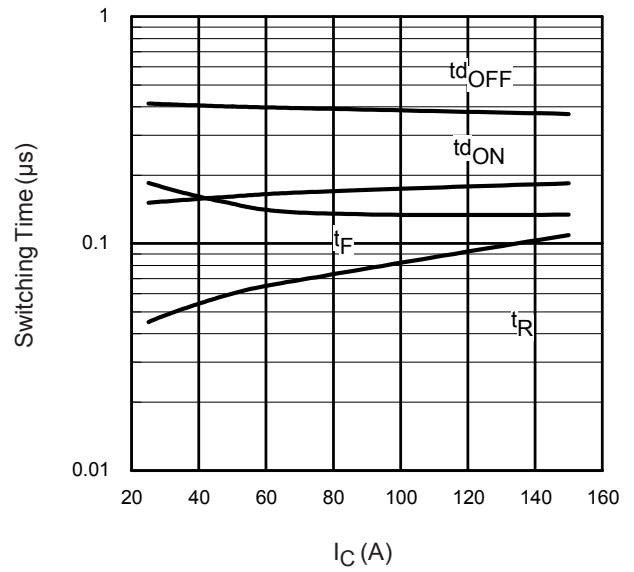

**Fig. 14** - Typ. Switching Time vs.  $I_C$   
 $T_J = 125^\circ\text{C}$ ;  $L = 200\mu\text{H}$ ;  $V_{CE} = 600\text{V}$   
 $R_G = 5\Omega$ ;  $V_{GE} = 15\text{V}$

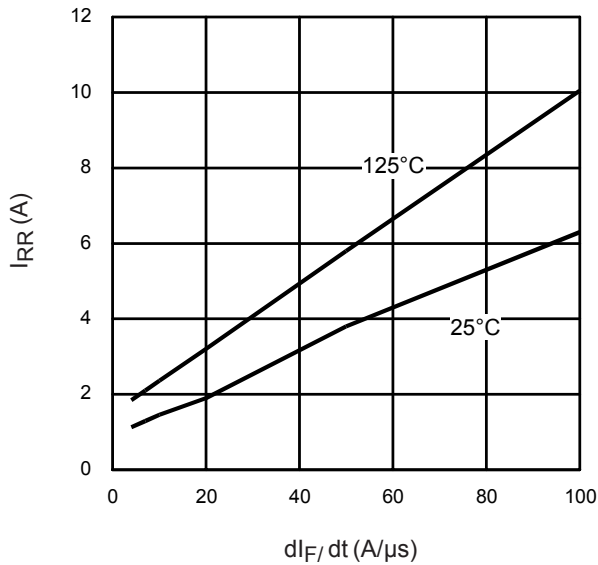

**Fig. 15**- Typical Diode  $I_{REC}$  vs.  $di_F/dt$   
 $V_{CC} = 600\text{V}$ ;  $I_F = 50\text{A}$

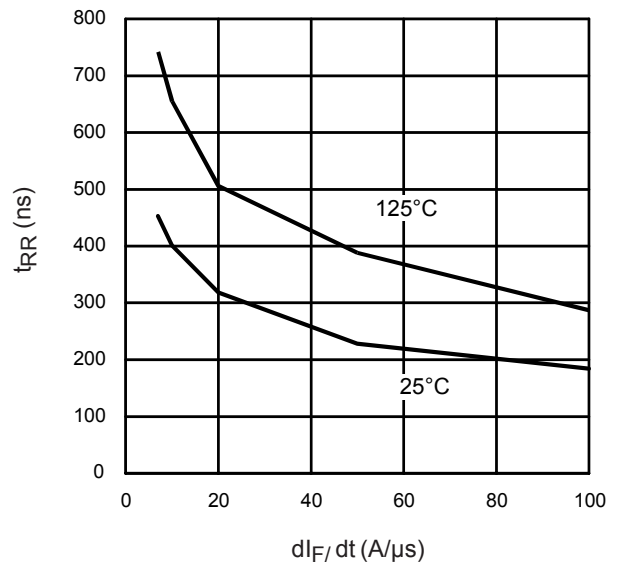

**Fig. 16**- Typical Diode  $t_{RR}$  vs.  $di_F/dt$   
 $V_{CC} = 600\text{V}$ ;  $I_F = 50\text{A}$

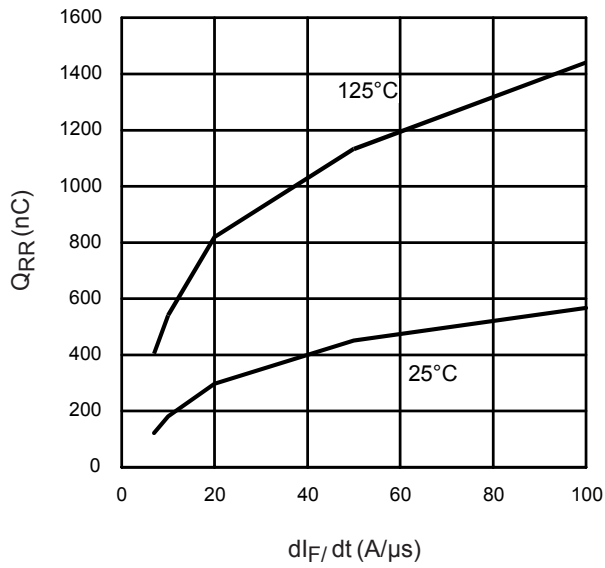

**Fig. 17-** Typical Diode  $Q_{RR}$  vs.  $di_F/dt$   
 $V_{CC} = 600V$ ;  $I_F = 50A$

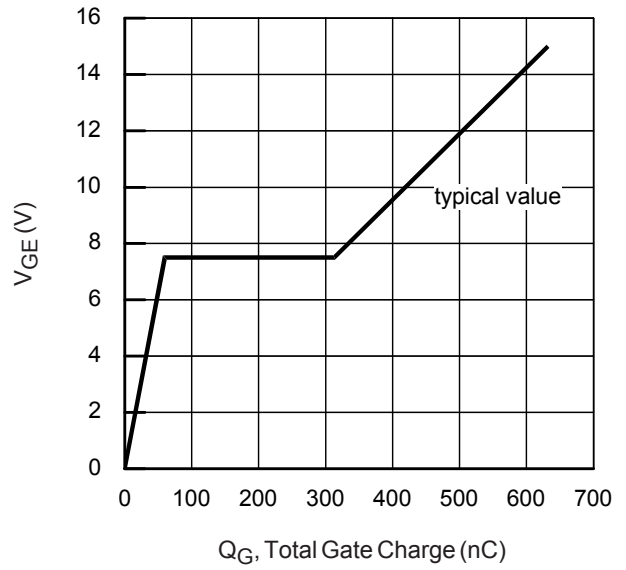

**Fig. 18 -** Typical Gate Charge vs.  $V_{GE}$   
 $I_{CE} = 5.0A$ ;  $L = 600\mu H$

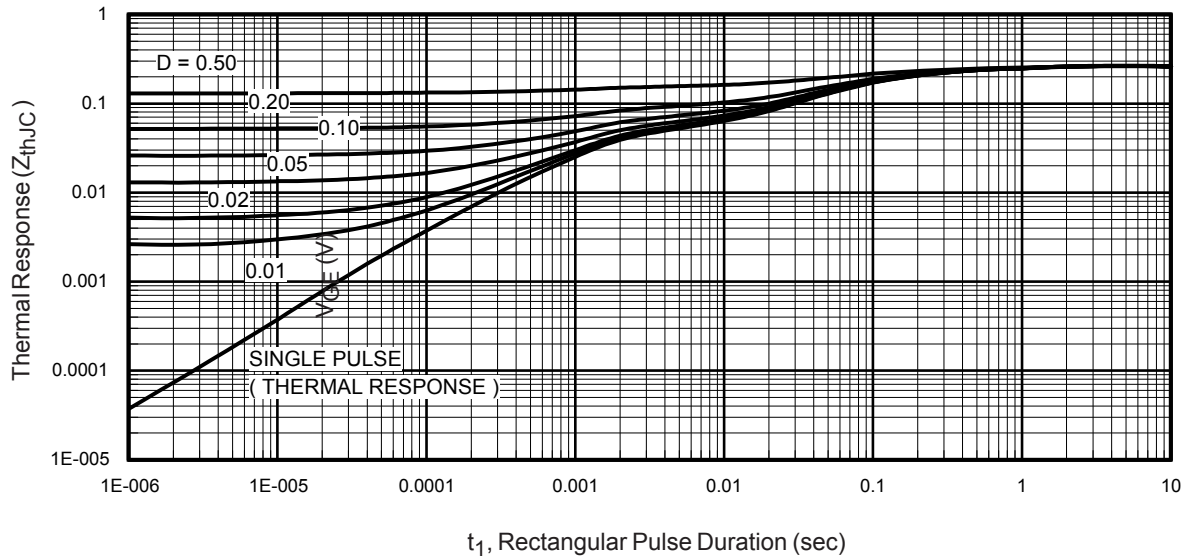

**Fig 19 -** Maximum Transient Thermal Impedance, Junction-to-Case (IGBT)

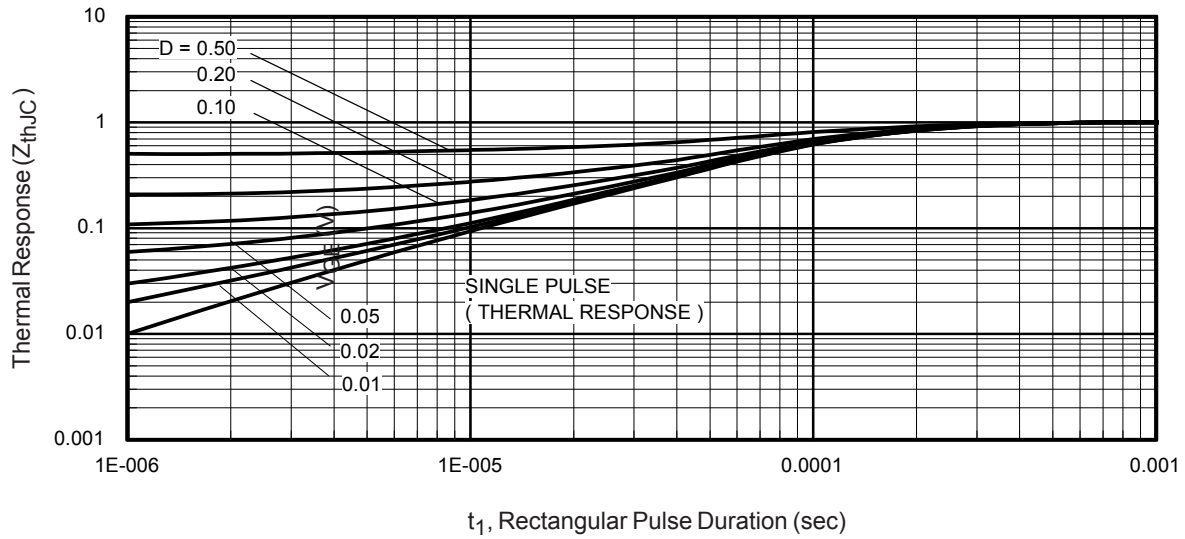

**Fig 20** - Maximum Transient Thermal Impedance, Junction-to-Case (DIODE)

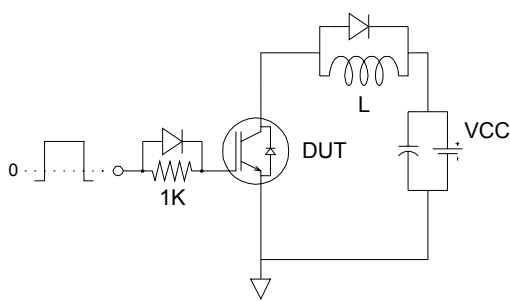

**Fig.C.T.1** - Gate Charge Circuit (turn-off)

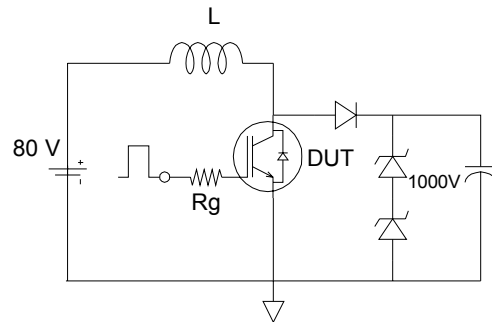

**Fig.C.T.2** - RBSOA Circuit

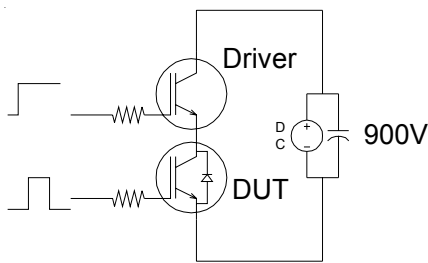

**Fig.C.T.3** - S.C. SOA Circuit

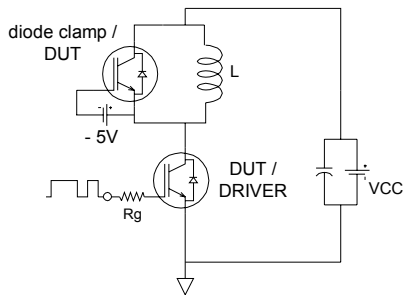

**Fig.C.T.4** - Switching Loss Circuit

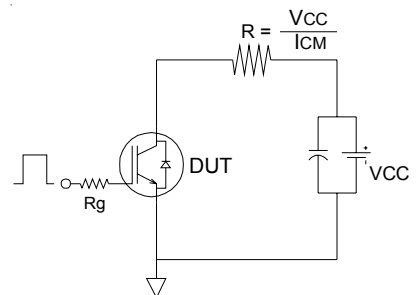

**Fig.C.T.5** - Resistive Load Circuit

