

### PRODUCT FEATURES

- Electrically Isolated by DBC Ceramic
- High Surge Current Capability
- Low Inductance Package

### APPLICATIONS

- DC Motor Control and Drives
- Battery Charges ,Heater controls,Light dimmers
- Static switches

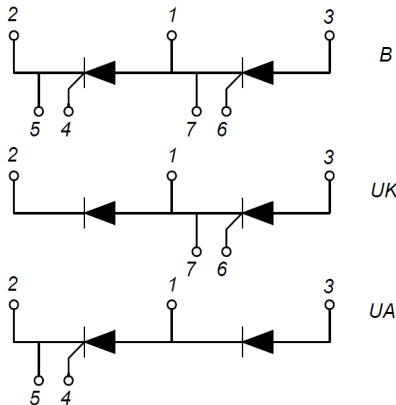

### MAXIMUM VOLTAGE RATINGS

$T_C = 25^\circ\text{C}$  unless otherwise specified

Module Type			$V_{RRM}/V_{DRM}$	$V_{RSM}$	Unit
MMK160S120B	MMK160S120UK	MMK160S120UA	1200	1300	V
MMK160S140B	MMK160S140UK	MMK160S140UA	1400	1500	
MMK160S160B	MMK160S160UK	MMK160S160UA	1600	1700	

### ABSOLUTE MAXIMUM RATINGS (Thyristor)

Symbol	Parameter/Test Conditions		Values	Unit
$I_{T(AV)}$	Average On State Current	Single phase, half wave, 180° conduction, $T_c = 80^\circ\text{C}$	160	A
$I_{T(RMS)}$	R.M.S. On State Current		250	
$I_{TSM}$	Non-Repetitive Surge On-State Current	1/2 cycle, 50/60HZ, peak value, $T_c = 45^\circ\text{C}$	3300/3600	
$I^2t$	For Fusing	1/2 cycle, 50/60HZ, peak value, $T_c = 45^\circ\text{C}$	54.4/53.7	KA <sup>2</sup> S
$T_J$	Junction Temperature(Thyristor)		-40 to +125	°C

### ABSOLUTE MAXIMUM RATINGS (Diode)

Symbol	Parameter/Test Conditions		Values	Unit
$I_{F(AV)}$	Average Forward Current	Single phase, half wave, 180° conduction, $T_c = 95^\circ\text{C}$	160	A
$I_{F(RMS)}$	R.M.S. Forward Current		250	
$I_{FSM}$	Non-Repetitive Surge Forward Current	1/2 cycle, 50/60HZ, peak value, $T_c = 45^\circ\text{C}$	5500/6000	
$I^2t$	For Fusing	1/2 cycle, 50/60HZ, peak value, $T_c = 45^\circ\text{C}$	151.2/149.4	KA <sup>2</sup> S
$T_J$	Junction Temperature(Diode)		-40 to +150	°C

**MacMic Science & Technology Co., Ltd.**

Add: #18, Hua Shan Zhong Lu, New District, Changzhou City, Jiangsu Province, P. R. of China  
 Tel.: +86-519-85163708 Fax: +86-519-85162291 Post Code: 213022 Website: www.macmicst.com

## ELECTRICAL CHARACTERISTICS (Thyristor)

 $T_C=25^\circ\text{C}$  unless otherwise specified

Symbol	Parameter/Test Conditions		Min.	Typ.	Max.	Unit
$I_{DRM}$	Maximum Peak Off-State Current	$V_D = V_{DRM}, T_J = 125^\circ\text{C}$			25	mA
$I_{RRM}$	Maximum Peak Reverse Current	$V_R = V_{RRM}, T_J = 125^\circ\text{C}$			25	
$V_{TM}$	Maximum on-state voltage drop	$I_{TM}=500\text{A}, t_d=10\text{ ms, half sine}$			1.75	V
$V_{TO}$	For power-loss calculations only	$T_J = 125^\circ\text{C}$			0.85	V
$r_T$					2.0	m $\Omega$
$V_{GT}$	Max. required DC gate voltage to trigger	$V_A=6\text{V}, R_A=1\Omega, T_J = -40^\circ\text{C}$			4.0	V
		$V_A=6\text{V}, R_A=1\Omega$		1.0	2.5	
		$V_A=6\text{V}, R_A=1\Omega, T_J = 125^\circ\text{C}$			1.7	
$I_{GT}$	Max. required DC gate current to trigger	$V_A=6\text{V}, R_A=1\Omega, T_J = -40^\circ\text{C}$			270	mA
		$V_A=6\text{V}, R_A=1\Omega$		75	150	
		$V_A=6\text{V}, R_A=1\Omega, T_J = 125^\circ\text{C}$			80	
$V_{GD}$	Max. required DC gate voltage not to trigger,	$V_D = V_{DRM}, T_J = 125^\circ\text{C}$			0.25	V
$I_{GD}$	Max. required DC gate current not to trigger,	$V_D = V_{DRM}, T_J = 125^\circ\text{C}$			6	mA
$I_H$	Maximum holding current			100	200	mA
$I_L$	Maximum latching current			200	400	mA
$P_{GM}$	Maximum peak gate power				12	W
$P_{G(AV)}$	Maximum average gate power				3.0	
$I_{GM}$	Maximum peak gate current				3.0	A
$-V_{GM}$	Maximum peak negative gate voltage				10	V
$dv/dt$	Critical Rate of Rise of Off-State Voltage, $T_J=125^\circ\text{C}$ , exponential to 67% rated $V_{DRM}$				1000	V/ $\mu\text{s}$
$di/dt$	Max. Rate of Rise of Turned-on Current, $T_J = 125^\circ\text{C}, I_{TM}=500\text{A}$ , rated $V_{DRM}$				150	A/ $\mu\text{s}$

## ELECTRICAL CHARACTERISTICS (Diode)

Symbol	Parameter/Test Conditions		Min.	Typ.	Max.	Unit
$I_{RM}$	Maximum Reverse Leakage Current	$V_R = V_{RRM}$			0.5	mA
		$V_R = V_{RRM}, T_J = 125^\circ\text{C}$			10	
$V_F$	Forward Voltage Drop	$I_F=500\text{A}$			1.5	V
$V_{TO}$	For power-loss calculations only, $T_J = 125^\circ\text{C}$				0.88	V
$r_T$					1.25	m $\Omega$

## MODULE CHARACTERISTICS

 $T_C=25^\circ\text{C}$  unless otherwise specified

$T_J$	Junction Temperature		-40 to +125	$^\circ\text{C}$
$T_{STG}$	Storage Temperature Range		-40 to +125	$^\circ\text{C}$
$V_{ISO}$	Isolation Breakdown Voltage	AC, 50Hz(R.M.S), $t=1\text{minute}$	3000	V
Torque	to heatsink	Recommended (M6)	3~5	N.m
Torque	to terminal	Recommended (M6)	3~5	N.m
$R_{th(J-C)}$	Junction-to-Case Thermal Resistance(Per Thyristor/Per Diode)		0.16/0.18	K/W
Weight			160	g

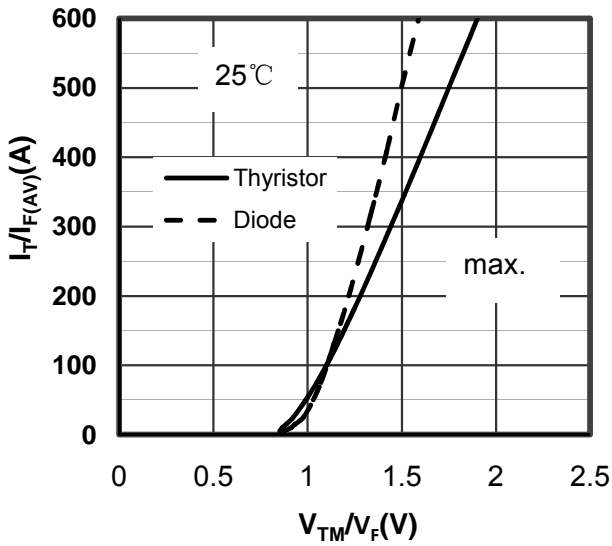

Figure1. Forward Voltage Drop vs Forward Current

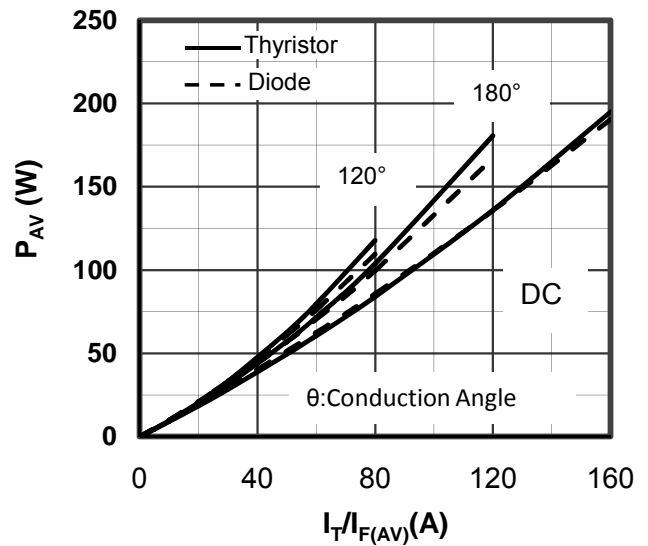

Figure2. Power dissipation vs.  $I_T/I_{F(AV)}$

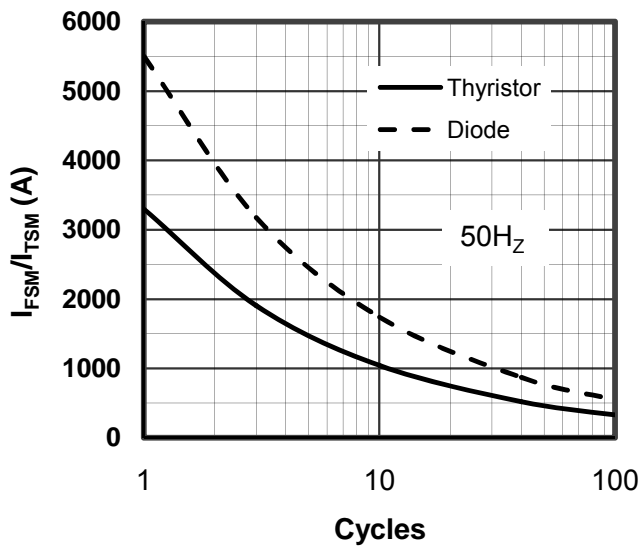

Figure3. Diode and SCR Max Non-Repetitive Surge

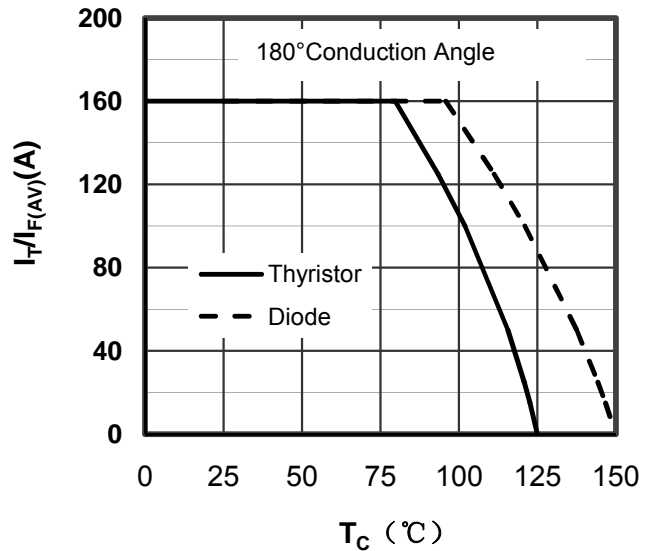

Figure4. Diode  $I_{F(AV)}$  and SCR  $I_{T(AV)}$  vs.  $T_c$

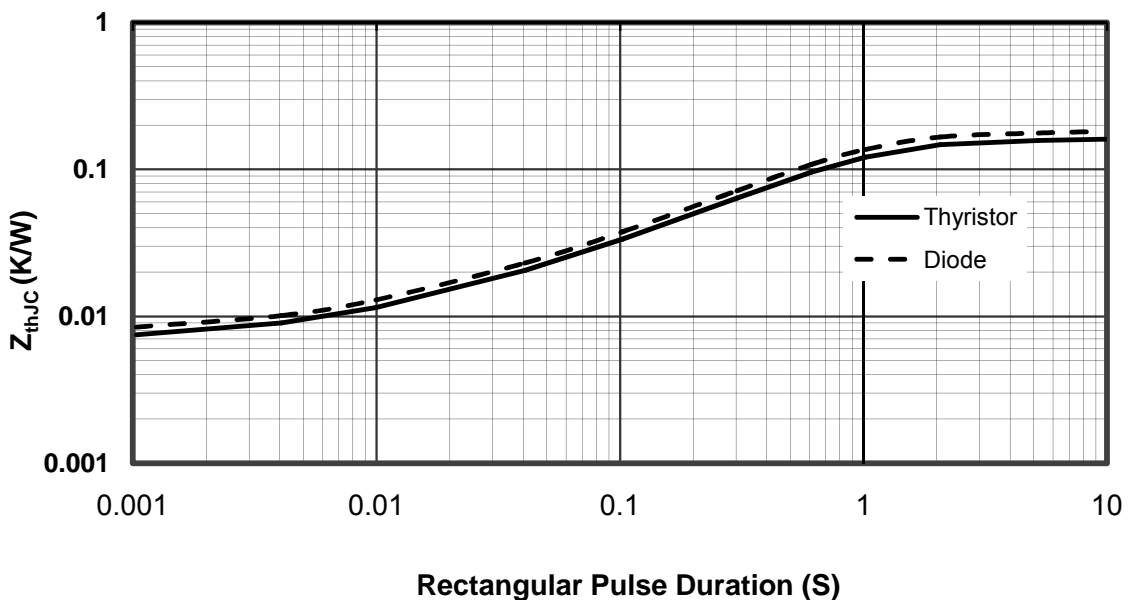

Figure5. Transient Thermal Impedance of Diode and SCR

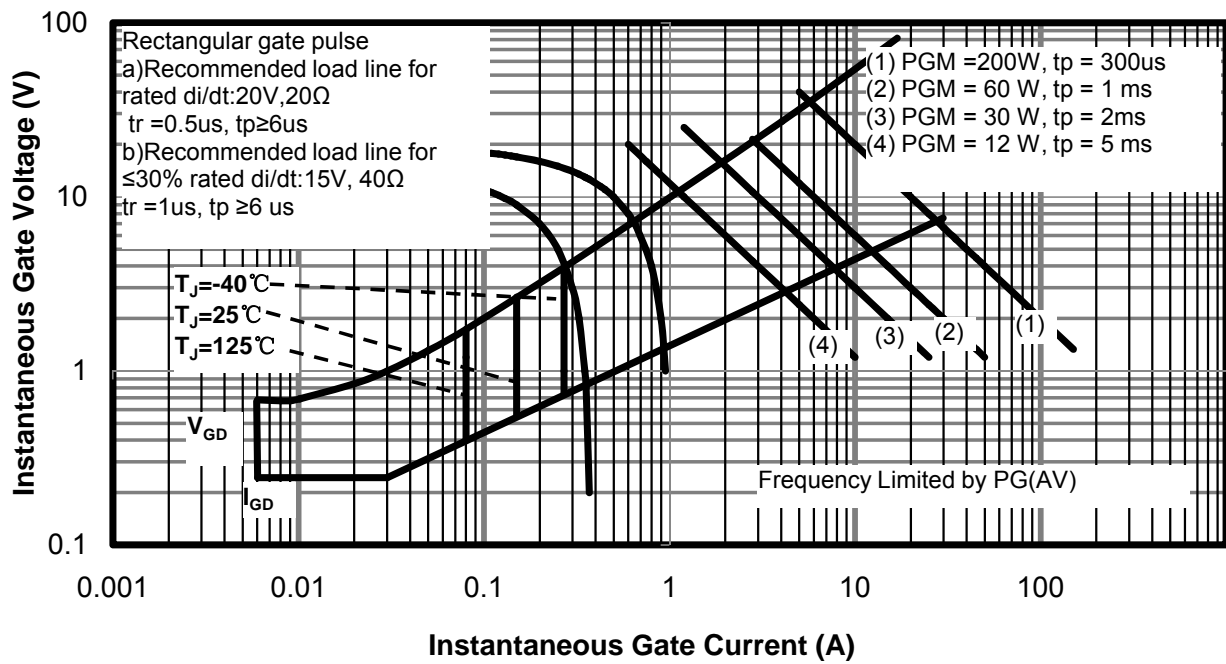
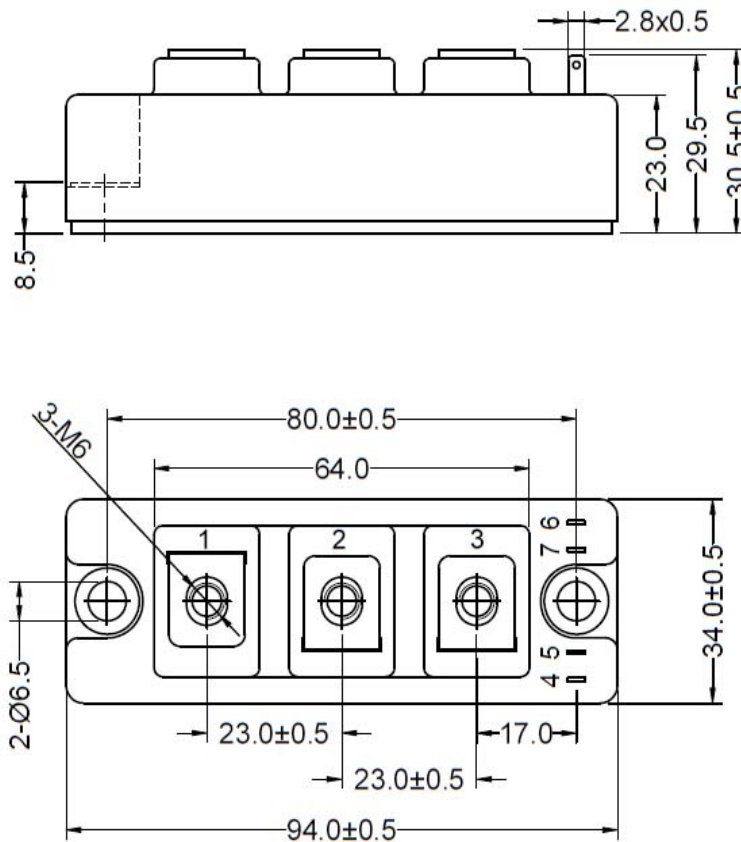

Figure 6. SCR Gate Characteristics



Dimensions in (mm)  
 Figure7. Package Outline