

PM200DHA120

FLAT-BASE TYPE
INSULATED PACKAGE

PM200DHA120

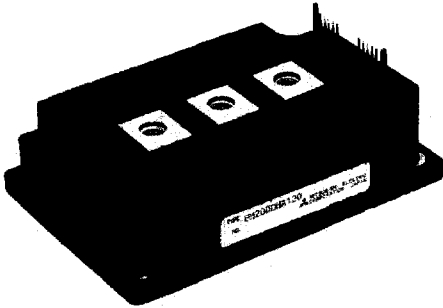

- 1φ 200A, 1200V Current-sense IGBT type inverter
- Monolithic gate drive & protection logic
- Detection, protection & status indication circuits for over-current, short-circuit, over-temperature & under-voltage
- Acoustic noise-less 30/37kW class inverter application
- UL Recognized

Yellow Card No. E80276 (N)
File No. E80271

APPLICATION

General purpose inverter, servo drives and other motor controls

OUTLINE DRAWING

Dimensions in mm

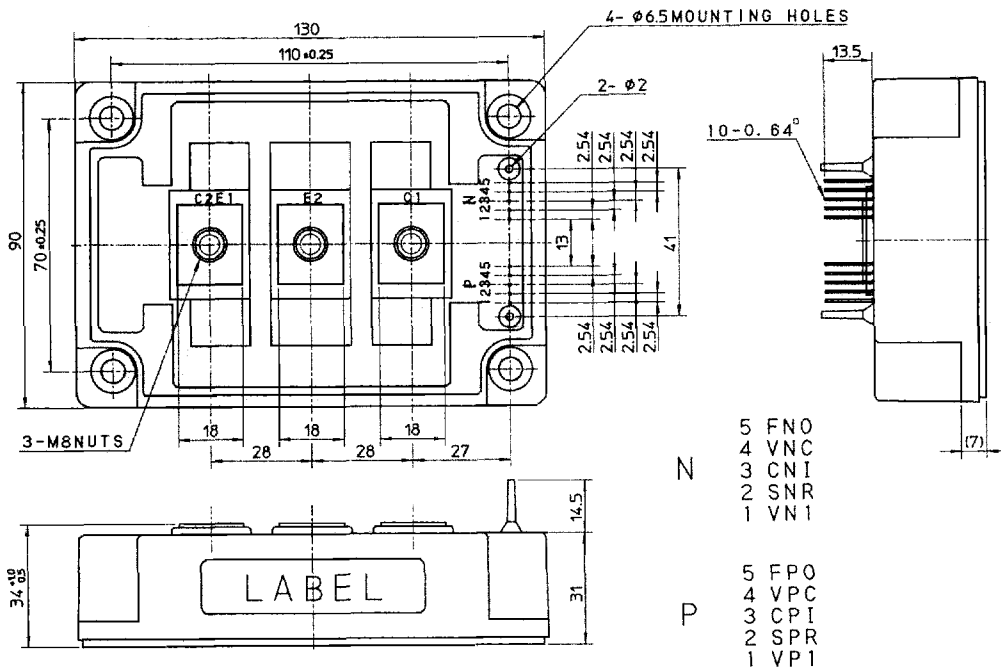

PM200DHA120

FLAT-BASE TYPE
INSULATED PACKAGE

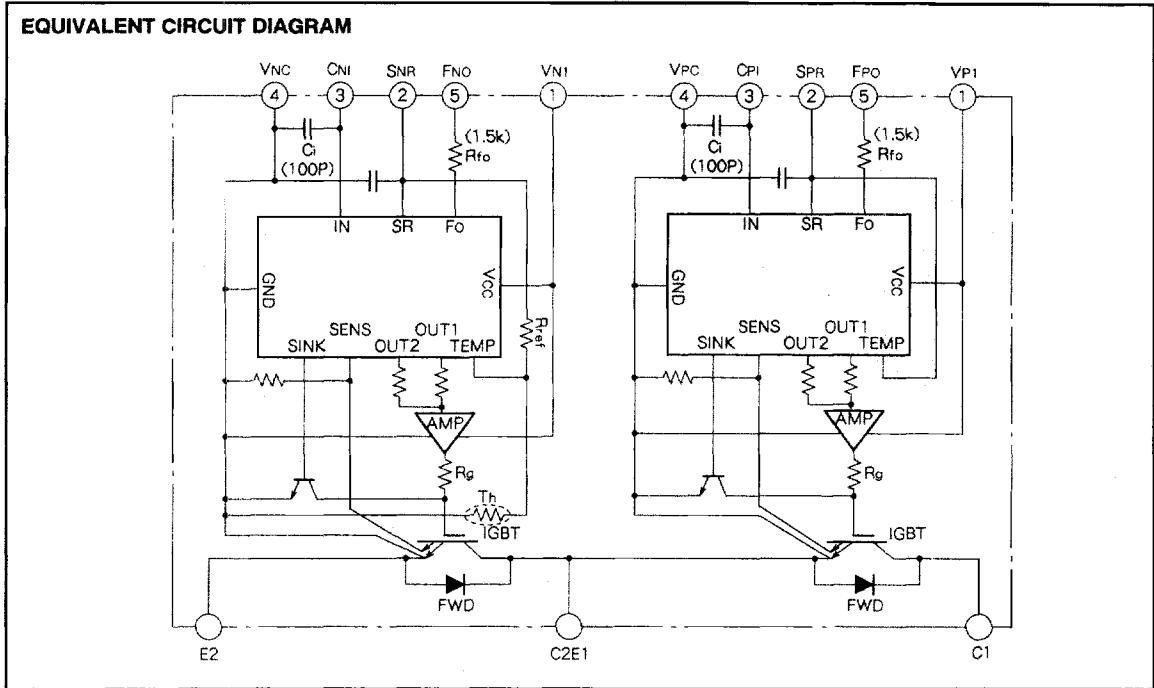

MAXIMUM RATINGS ($T_j = 25^\circ\text{C}$, unless otherwise noted)

INVERTER PART

Symbol	Parameter	Conditions	Ratings	Unit
V_{CC}	Supply voltage	Applied between : C1-E2	900	V
$V_{CC(surge)}$	Supply voltage (surge)	Applied between : C1-E2, surge value	1000	V
V_{CES}	Collector-emitter voltage		1200	V
$\pm I_C$	Collector current	$T_c = 25^\circ\text{C}$	200	A
$\pm I_{CP}$	Collector current (peak)	$T_c = 25^\circ\text{C}$	400	A
P_C	Collector dissipation	$T_c = 25^\circ\text{C}$	1470	W
T_j	Junction temperature		-20~+150	$^\circ\text{C}$

CONTROL PART

Symbol	Parameter	Conditions	Ratings	Unit
V_D	Supply voltage	Applied between : VP1-VPC, VN1-VNC	20	V
V_{CIN}	Input voltage	Applied between : CPI-VPC, CNI-VNC	10	V
V_{FO}	Fault output supply voltage	Applied between : FPO-VPC, FNO-VNC	20	V
I_{FO}	Fault output current	Sink current of FPO, FNO terminals	20	mA

PM200DHA120

**FLAT-BASE TYPE
INSULATED PACKAGE**

TOTAL SYSTEM

Symbol	Parameter	Conditions	Ratings	Unit
V _{CC(Prot)}	Supply voltage protected by OC & SC	V _D = 13.5~16.5V Inverter part, T _J = 125 °C start	800	V
T _C	Module case operating temperature		- 20~ + 100	°C
T _{stg}	Storage temperature		- 40~ + 125	°C
V _{iso}	Isolation voltage	60Hz, sinusoidal, AC, 1min	2500	V _{rms}

ELECTRICAL CHARACTERISTICS (T_J = 25 °C, unless otherwise noted)

INVERTER PART

Symbol	Parameter	Test conditions	Limits			Unit
			Min	Typ	Max	
V _{CE(sat)}	Collector-emitter saturation voltage	V _D = 15V, V _{CIN} = 0V Pulsed				V
		I _C = 200A, T _J = 25 °C	-	2.8	3.8	
		I _C = 200A, T _J = 125 °C	-	2.4	3.4	
V _{EC}	FWDi forward voltage	- I _C = 200A, V _{CIN} = 5V	-	1.8	3.0	V
t _{on}	Switching time	V _D = 15V, V _{CIN} = 0V ↔ 5V V _{CC} = 600V, I _C = 200A T _J = 125 °C (Per 1arm) Inductive load	0.5	1.4	2.5	μs
t _{rr}			-	0.3	0.6	μs
t _{c(on)}			-	0.4	1.0	μs
t _{off}			-	3.5	4.0	μs
t _{c(off)}			-	0.8	1.2	μs
I _{CES}	Collector-emitter cutoff current	V _{CE} = V _{CES} , V _{CIN} = 5V				mA
		T _J = 25 °C	-	-	1	
		T _J = 125 °C	-	-	10	

CONTROL PART

Symbol	Parameter	Test conditions	Limits			Unit
			Min	Typ	Max	
V _D	Supply voltage	Applied between : V _{P1} -V _{PC} , V _{N1} -V _{NC}	13.5	15	16.5	V
I _D	Circuit current	V _D = 15V, V _{CIN} = 5V				mA
		V _{N1} -V _{NC} V _{P1} -V _{PC}	-	23	30	
V _{CIN(ON)}	Input on threshold voltage	Applied between : C _{P1} -V _{PC} , C _{N1} -V _{NC}	1.2	1.5	1.8	V
V _{CIN(OFF)}	Input off threshold voltage		1.7	2.0	2.3	V
f _{PWM}	PWM input frequency	3φ sinusoidal	-	15	20	kHz
t _{dead}	Arm shoot-through blocking time	For IPM's each input signals	4	-	-	μs
		Using application circuit I _F = 12mA	6	-	-	
OC	Over current trip level	T _J ≤ 125 °C, V _D = 15V	240	360	-	A
SC	Short circuit trip level	T _J ≤ 125 °C, V _D = 15V	320	540	-	A
t _{off(oc)}	Over current delay time	V _D = 15V	-	5	-	μs
OT	Over temperature protection	Trip level	100	110	120	°C
		Reset level	85	95	105	
UV	Supply circuit under voltage protection	Trip level	11.5	12.0	12.5	V
		Reset level	-	12.5	-	
I _{FO(H)}	Fault output current (Note 1)	V _D = 15V, V _{FO} = 15V	-	-	0.01	mA
I _{FO(L)}			-	10	15	
t _{FO}	Minimum fault output pulse width (Note 1)	V _D = 15V	1.0	1.8	-	ms
V _{SXR}	SXR terminal output voltage	T _J ≤ 125 °C, R _{in} = 6.8k Ω, (SPR, SNR)	4.5	5.1	5.6	V

Note 1. Fault output is given only when the internal OC, SC, OT & UV protections schemes of either upper or lower arm device operate to protect it.

PM200DHA120

**FLAT-BASE TYPE
INSULATED PACKAGE**

THERMAL RESISTANCES

Symbol	Parameter	Test conditions	Limits			Unit
			Min	Typ	Max	
$R_{th(j-c)\Omega}$	Junction to case thermal resistances	Inverter IGBT part, per 1/2 module	-	-	0.085	°C/W
$R_{th(j-c)F}$		Inverter FWDi part, per 1/2 module	-	-	0.18	°C/W
$R_{th(c-f)}$	Contact thermal resistance	Thermal grease applied, per 1/2 module	-	-	0.060	°C/W

MECHANICAL RATINGS AND CHARACTERISTICS

Symbol	Parameter	Test conditions	Limits			Unit
			Min	Typ	Max	
-	Mounting torque	Mounting part screw : M6	1.96	2.45	2.94	N · m
-	Mounting torque	Main terminals part screw : M8	20	25	30	kg · cm
-	Weight		8.83	9.81	10.8	N · m
-			90	100	110	kg · cm
-			-	910	-	g

RECOMMENDED CONDITIONS FOR USE

Symbol	Parameter	Test conditions	Value			Unit
			Min	Typ	Max	
V_{CC}	Supply voltage	Applied across C1-E2 terminals	0	600	800	V
V_D		Applied between : $V_{P1-V_{PC}}$, $V_{N1-V_{NC}}$	13.5	15	16.5	V
$V_{CIN(ON)}$	Input on voltage	Applied between : $C_{P1-V_{PC}}$, $C_{N1-V_{NC}}$	0	-	0.8	V
$V_{CIN(OFF)}$	Input off voltage		4	-	V_{SXR}	V
f_{PWM}	PWM input frequency	Using application circuit	5	15	20	kHz
t_{dead}	Arm shoot-through blocking time	Using application circuit opto-coupler's input signal	6	-	-	μs

PM200DHA120

FLAT-BASE TYPE
INSULATED PACKAGE

PERFORMANCE CURVES

OUTPUT CHARACTERISTICS (TYPICAL)

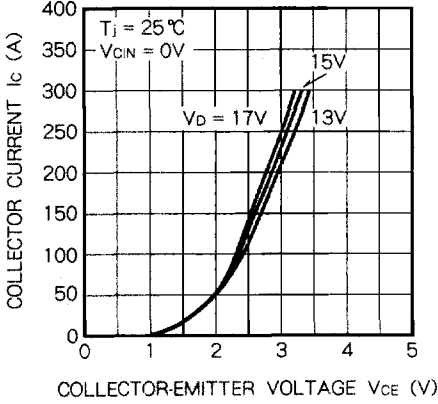

SATURATION VOLTAGE CHARACTERISTICS (TYPICAL)

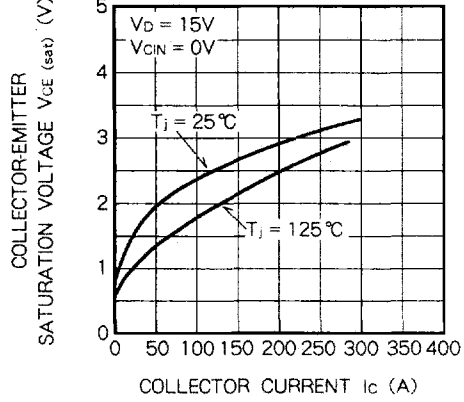

COLLECTOR-EMITTER SATURATION VOLTAGE (TYPICAL)

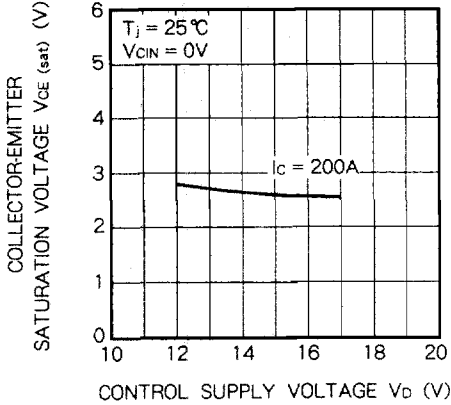

FREE-WHEEL DIODE FORWARD CHARACTERISTICS (TYPICAL)

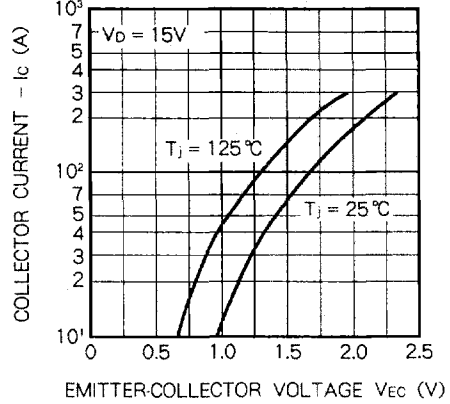

SWITCHING TIME VS. COLLECTOR CURRENT (TYPICAL)

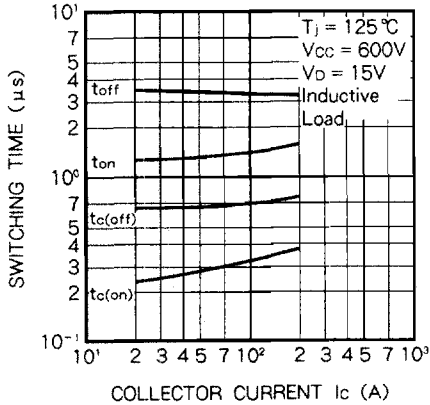

REVERSE RECOVERY CHARACTERISTICS OF FREE-WHEEL DIODE (TYPICAL)

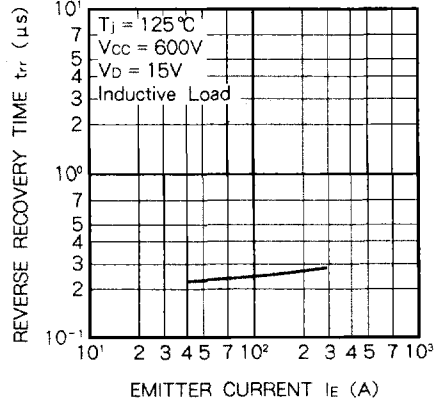

PM200DHA120

FLAT-BASE TYPE
INSULATED PACKAGE

POWER DISSIPATION DERATING CURVE
(Per IGBT element)

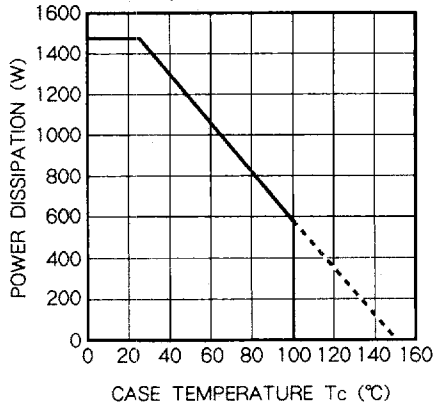

POWER DISSIPATION DERATING CURVE
(Per FWDi element)

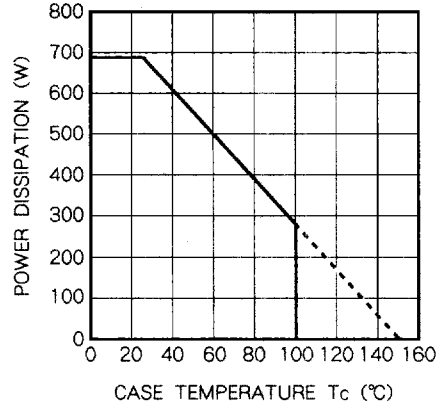

TRANSIENT THERMAL
IMPEDANCE CHARACTERISTICS
(IGBT part)

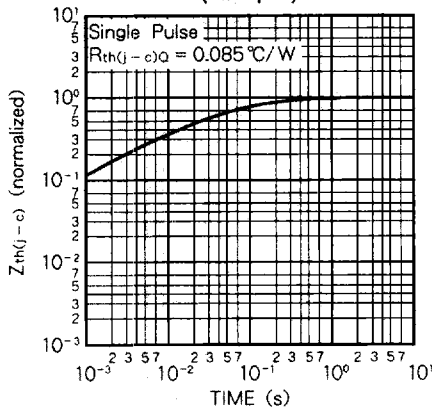

TRANSIENT THERMAL
IMPEDANCE CHARACTERISTICS
(FWDi part)

