

SKM300MLI066TAT



SEMITRANS[®] 5

Trench IGBT Modules

SKM300MLI066TAT

Features

- Homogeneous Si
- Trench = Trenchgate technology
- $V_{CE(sat)}$ with positive temperature coefficient
- Integrated NTC temperature sensor

Typical Applications*

- UPS
- 3 Level Inverter

Remarks

- Case temperature limited to $T_c = 125^\circ\text{C}$ max
- Recommended $T_{op} = -40..+150^\circ\text{C}$ for IGBT;
- $T_{op} = -40..+125^\circ\text{C}$ for diode
- T_{vj} is intended as absolute maximum rating, limited by diode
- Fig.2 is referred to IGBT current capability

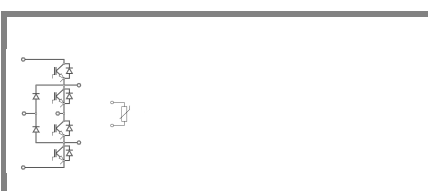

MLI-TAT

Absolute Maximum Ratings		$T_{case} = 25^\circ\text{C}$, unless otherwise specified		
Symbol	Conditions	Values	Units	
IGBT				
V_{CES}	$T_j = 25^\circ\text{C}$	600	V	
I_C	$T_j = 175^\circ\text{C}$	$T_c = 25^\circ\text{C}$	400	A
		$T_c = 80^\circ\text{C}$	300	A
I_{CRM}	$I_{CRM} = 2 \times I_{Cnom}$	600	A	
V_{GES}		± 20	V	
t_{psc}	$V_{CC} = 360\text{ V}; V_{GE} \leq 15\text{ V}; T_j = 150^\circ\text{C}$ $V_{CES} < 600\text{ V}$	6	μs	
Inverse Diode				
I_F	$T_j = 150^\circ\text{C}$	$T_c = 25^\circ\text{C}$	324	A
		$T_c = 80^\circ\text{C}$	211	A
I_{FRM}	$I_{FRM} = 2 \times I_{Fnom}$	420	A	
I_{FSM}	$t_p = 10\text{ ms};$ half sine wave $T_j = 150^\circ\text{C}$	2100	A	
Freewheeling Diode				
I_F	$T_j = 150^\circ\text{C}$	$T_c = 25^\circ\text{C}$	324	A
		$T_c = 80^\circ\text{C}$	211	A
I_{FRM}	$I_{FRM} = 2 \times I_{Fnom}$	420	A	
I_{FSM}	$t_p = 10\text{ ms};$ half sine wave $T_j = 150^\circ\text{C}$	2100	A	
Module				
$I_{t(RMS)}$		500	A	
T_{vj}		- 40 ... + 150	$^\circ\text{C}$	
T_{stg}		- 40 ... + 125	$^\circ\text{C}$	
V_{isol}	AC, 1 min.	2500	V	

Characteristics		$T_{case} = 25^\circ\text{C}$, unless otherwise specified				
Symbol	Conditions	min.	typ.	max.	Units	
IGBT						
$V_{GE(th)}$	$V_{GE} = V_{CE}, I_C = 4,8\text{ mA}$	5	5,8	6,5	V	
I_{CES}	$V_{GE} = 0\text{ V}, V_{CE} = V_{CES}$ $T_j = 25^\circ\text{C}$			0,5	mA	
I_{GES}	$V_{CE} = 0\text{ V}, V_{GE} = 20\text{ V}$ $T_j = 25^\circ\text{C}$			1200	nA	
V_{CE0}			$T_j = 25^\circ\text{C}$	0,9	1	V
			$T_j = 150^\circ\text{C}$	0,85	0,9	V
r_{CE}	$V_{GE} = 15\text{ V}$		$T_j = 25^\circ\text{C}$	1,8	3	$\text{m}\Omega$
			$T_j = 150^\circ\text{C}$	2,7	3,8	$\text{m}\Omega$
$V_{CE(sat)}$	$I_{Cnom} = 300\text{ A}, V_{GE} = 15\text{ V}$		$T_j = 25^\circ\text{C}_{chiplev.}$	1,45	1,9	V
			$T_j = 150^\circ\text{C}_{chiplev.}$	1,7	2,1	V
C_{ies}	$V_{CE} = 25, V_{GE} = 0\text{ V}$	$f = 1\text{ MHz}$		18,4		nF
C_{oes}				1,14		nF
C_{res}				0,54		nF
Q_G	$V_{GE} = -15\text{V}...+15\text{V}$		3900		nC	
R_{Gint}	$T_j = ^\circ\text{C}$		1		Ω	
$t_{d(on)}$	$R_{Gon} = 2,2\ \Omega$ $di/dt = 3400\text{ A}/\mu\text{s}$	$V_{CC} = 300\text{V}$ $I_C = 300\text{A}$		140		ns
t_r				89		ns
E_{on}				3,5		mJ
$t_{d(off)}$	$R_{Goff} = 2,2\ \Omega$ $di/dt = 3400\text{ A}/\mu\text{s}$	$T_j = 125^\circ\text{C}$ $V_{GE} =$ $--15\text{V}/+15\text{V}$		433		ns
t_f				116		ns
E_{off}				10,1		mJ
$R_{th(j-c)}$	per IGBT		0,15			K/W

SKM300MLI066TAT



SEMITRANS[®] 5

Trench IGBT Modules

SKM300MLI066TAT

Features

- Homogeneous Si
- Trench = Trenchgate technology
- $V_{CE(sat)}$ with positive temperature coefficient
- Integrated NTC temperature sensor

Typical Applications*

- UPS
- 3 Level Inverter

Remarks

- Case temperature limited to $T_c = 125^\circ\text{C}$ max
- Recommended $T_{op} = -40..+150^\circ\text{C}$ for IGBT;
 $T_{op} = -40..+125^\circ\text{C}$ for diode
- T_{vj} is intended as absolute maximum rating, limited by diode
- Fig.2 is referred to IGBT current capability

Characteristics			min.	typ.	max.	Units
Symbol	Conditions					
Inverse Diode						
$V_F = V_{EC}$	$I_{Fnom} = 245\text{ A}; V_{GE} = 0\text{ V}$	$T_j = 25^\circ\text{C}_{chiplev.}$		1,35	1,6	V
		$T_j = 125^\circ\text{C}_{chiplev.}$		1,35	1,6	V
V_{F0}		$T_j = 25^\circ\text{C}$		1	1,1	V
		$T_j = 125^\circ\text{C}$		0,9	1	V
r_F		$T_j = 25^\circ\text{C}$		1,42	2	mΩ
		$T_j = 125^\circ\text{C}$		1,8	2,4	mΩ
I_{RRM}	$I_F = 245\text{ A}$	$T_j = 125^\circ\text{C}$				A
Q_{rr}						μC
E_{rr}	$V_{GE} = -8\text{ V}; V_{CC} = 300\text{ V}$					mJ
$R_{th(j-c)D}$	per diode			0,28		K/W
Free-wheeling diode (Neutral Clamp Diode)						
$V_F = V_{EC}$	$I_{Fnom} = 245\text{ A}; V_{GE} = 0\text{ V}$	$T_j = 25^\circ\text{C}_{chiplev.}$		1,35	1,6	V
		$T_j = 125^\circ\text{C}_{chiplev.}$		1,35	1,6	V
V_{F0}		$T_j = 25^\circ\text{C}$		1	1,1	V
		$T_j = 125^\circ\text{C}$		0,9	1	V
r_F		$T_j = 25^\circ\text{C}$		1,42	2	V
		$T_j = 125^\circ\text{C}$		1,8	2,4	V
I_{RRM}	$I_F = 300\text{ A}$	$T_j = 125^\circ\text{C}$		194		A
Q_{rr}	$di/dt = 3400\text{ A}/\mu\text{s}$			13		μC
E_{rr}	$V_{GE} = 0\text{ V}; V_{CC} = 300\text{ V}$			4		mJ
$R_{th(j-c)FD}$	per diode			0,28		K/W
$R_{th(c-s)}$	per module				0,038	K/W
M_s	to heat sink M6		3		5	Nm
M_t	to terminals M6		2,5		5	Nm
w					310	g
Temperature sensor						
R_{100}	$T_s = 100^\circ\text{C}$ ($R_{25} = 5\text{ k}\Omega$)			493±5%		Ω
						K

This is an electrostatic discharge sensitive device (ESDS), international standard IEC 60747-1, Chapter IX.

* The specifications of our components may not be considered as an assurance of component characteristics. Components have to be tested for the respective application. Adjustments may be necessary. The use of SEMIKRON products in life support appliances and systems is subject to prior specification and written approval by SEMIKRON. We therefore strongly recommend prior consultation of our staff.



MLI-TAT

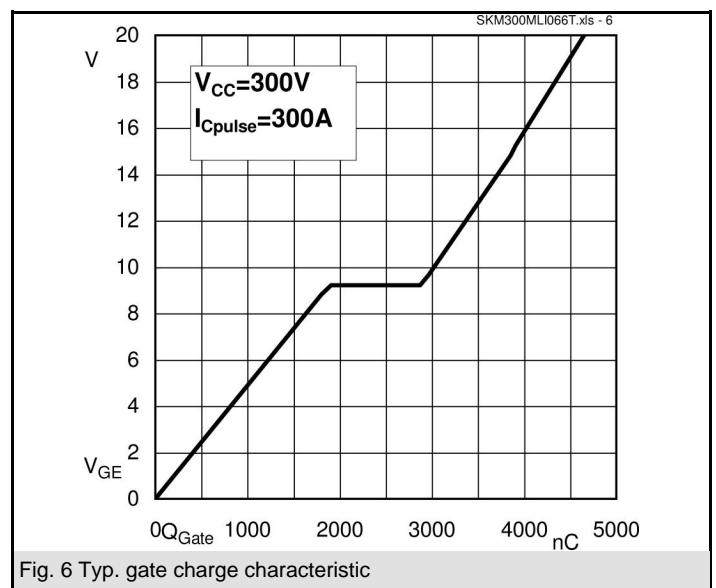
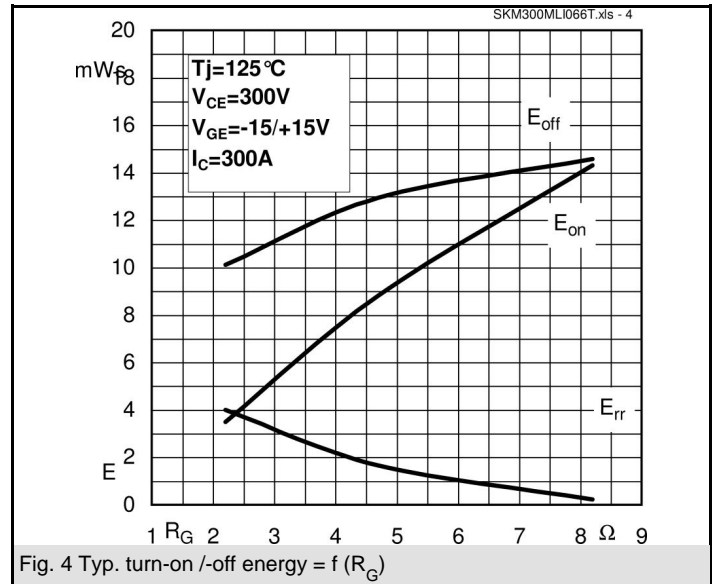
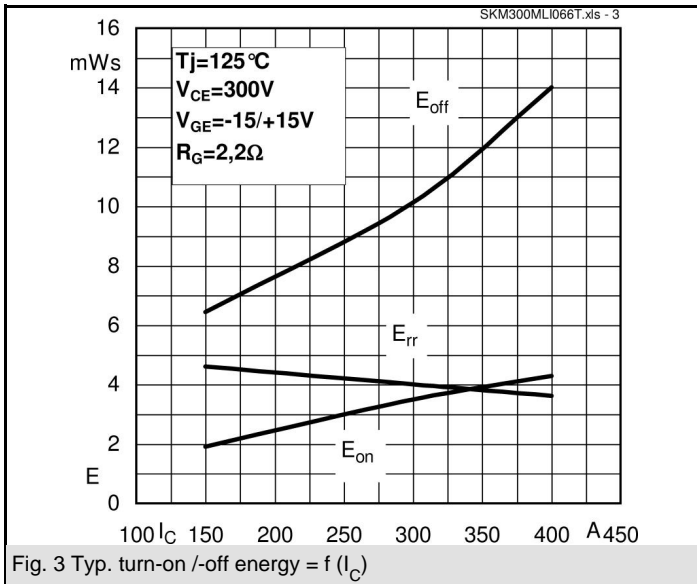
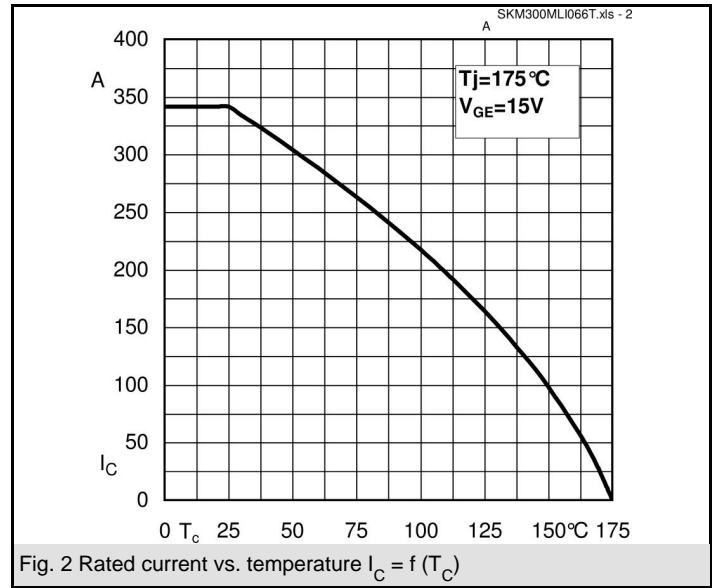
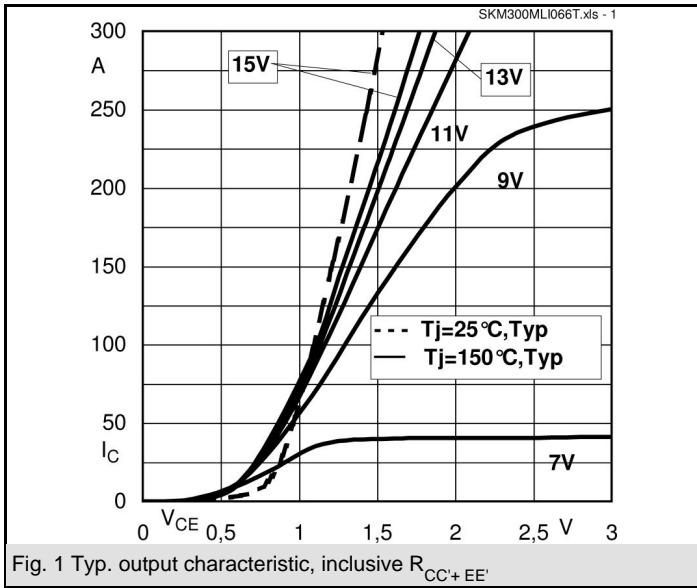

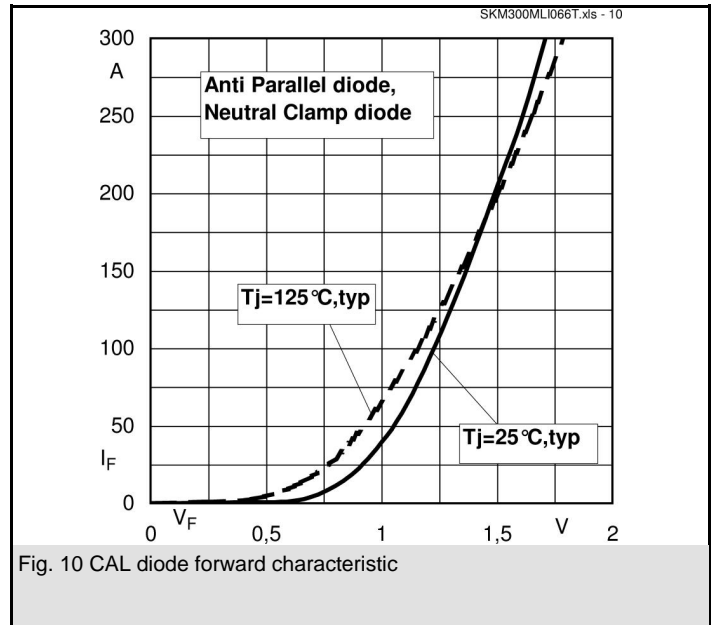
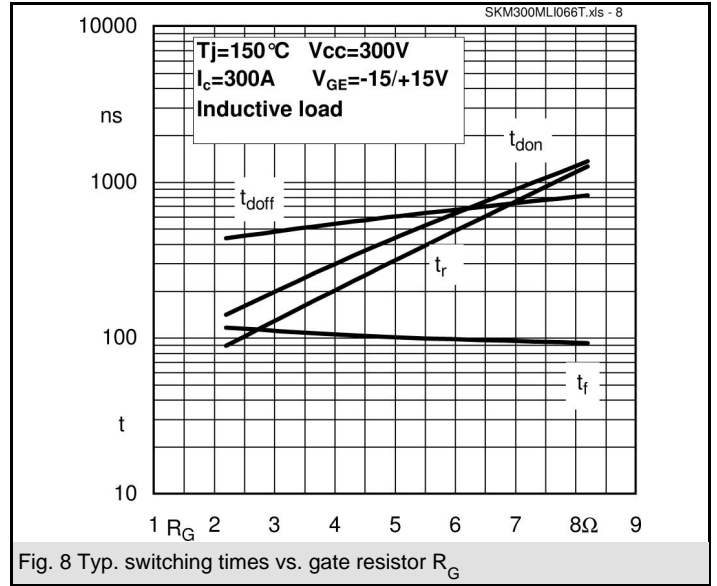
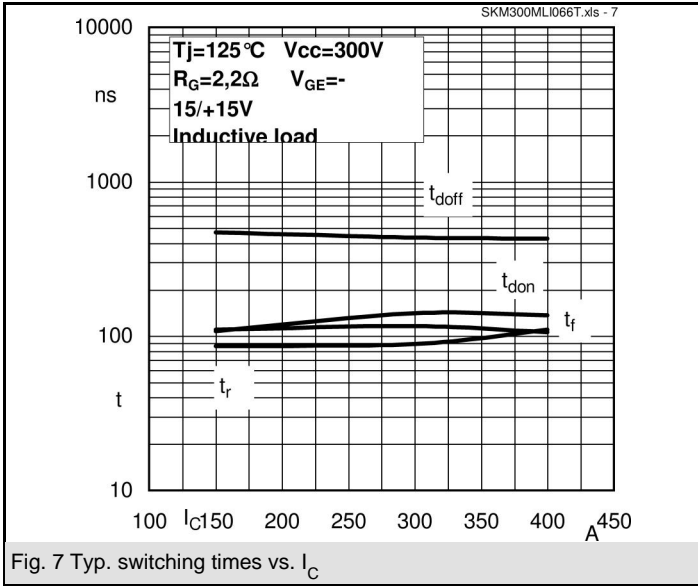

SKM300MLI066TAT

UL recognized

file no. E 63 532

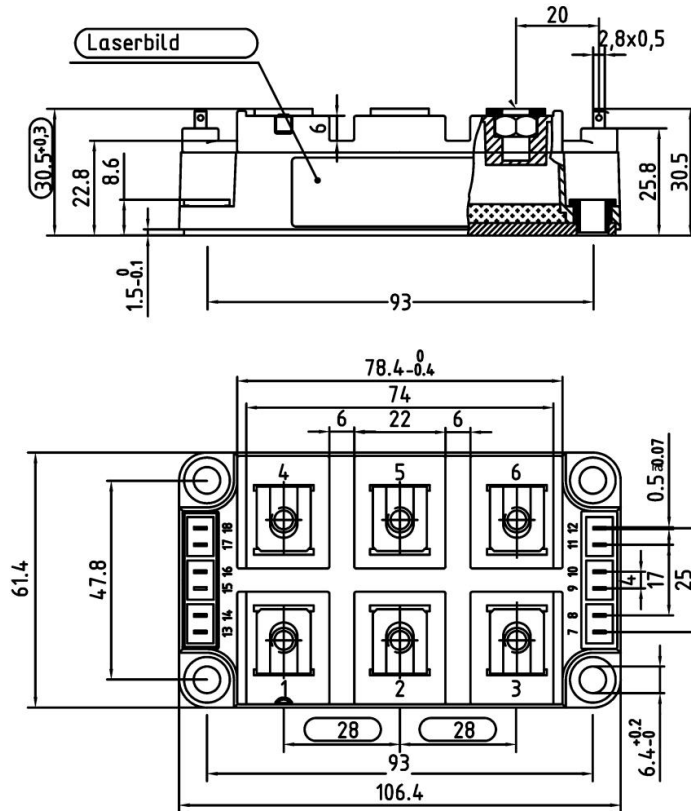

Case D62

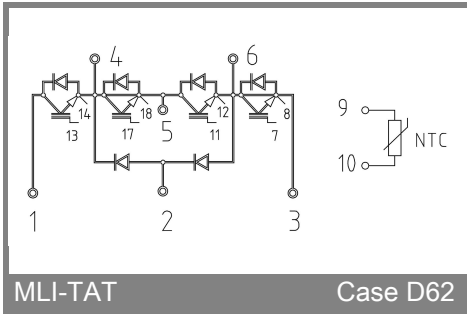

MLI-TAT

Case D62