

## SEMITRANS® M IGBT Modules

**SKM 75 GB 123 D**  
**SKM 75 GAL 123 D** <sup>6)</sup>  
**SKM 75 GAR 123 D** <sup>6)</sup>

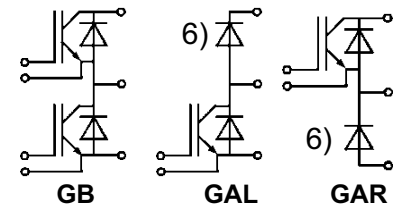

### SEMITRANS 2



#### Features

- MOS input (voltage controlled)
- N channel, Homogeneous Si
- Low inductance case
- Very low tail current with low temperature dependence
- High short circuit capability, self limiting to  $6 \cdot I_{cnom}$
- Latch-up free
- Fast & soft inverse CAL diodes<sup>8)</sup>
- Isolated copper baseplate using DCB Direct Copper Bonding Technology
- Large clearance (10 mm) and creepage distances (20 mm).

#### Typical Applications: → B 6 - 91

- Switching (not for linear use)

<sup>1)</sup>  $T_{case} = 25\text{ °C}$ , unless otherwise specified

<sup>2)</sup>  $I_F = -I_C$ ,  $V_R = 600\text{ V}$ ,  $-di_F/dt = 800\text{ A}/\mu\text{s}$ ,  $V_{GE} = 0\text{ V}$

<sup>3)</sup> Use  $V_{GEOff} = -5 \dots -15\text{ V}$

<sup>5)</sup> See fig. 2 + 3;  $R_{Goff} = 22\ \Omega$

<sup>6)</sup> The free-wheeling diodes of the GAL and GAR types have the data of the inverse diodes of SKM 100 GB 123 D

<sup>8)</sup> CAL = Controlled Axial Lifetime Technology.

#### Cases and mech. data → B6 - 92 SEMITRANS 2

Absolute Maximum Ratings		Values		Units
Symbol	Conditions <sup>1)</sup>			
$V_{CES}$		1200		V
$V_{CGR}$	$R_{GE} = 20\text{ k}\Omega$	1200		V
$I_C$	$T_{case} = 25/80\text{ °C}$	75 / 60		A
$I_{CM}$	$T_{case} = 25/80\text{ °C}$ ; $t_p = 1\text{ ms}$	150 / 120		A
$V_{GES}$		$\pm 20$		V
$P_{tot}$	per IGBT, $T_{case} = 25\text{ °C}$	460		W
$T_j, (T_{stg})$		- 40 ... +150 (125)		°C
$V_{isol}$	AC, 1 min.	2 500		V
humidity	IEC 60721-3-3	Class 3K7/IE32		
climate	IEC 68 T.1	40/125/56		
Inverse Diode		FWD <sup>6)</sup>		
$I_F = -I_C$	$T_{case} = 25/80\text{ °C}$	75 / 50	95 / 65	A
$I_{FM} = -I_{CM}$	$T_{case} = 25/80\text{ °C}$ ; $t_p = 1\text{ ms}$	150 / 120	150 / 120	A
$I_{FSM}$	$t_p = 10\text{ ms}$ ; sin.; $T_j = 150\text{ °C}$	550	720	A
$I^2t$	$t_p = 10\text{ ms}$ ; $T_j = 150\text{ °C}$	1500	2600	A <sup>2</sup> s

Characteristics		min.	typ.	max.	Units
Symbol	Conditions <sup>1)</sup>				
$V_{(BR)CES}$	$V_{GE} = 0$ , $I_C = 4\text{ mA}$	$\geq V_{CES}$	-	-	V
$V_{GE(th)}$	$V_{GE} = V_{CE}$ , $I_C = 2\text{ mA}$	4,5	5,5	6,5	V
$I_{CES}$	$V_{GE} = 0$ } $T_j = 25\text{ °C}$	-	0,8	1	mA
	$V_{CE} = V_{CES}$ } $T_j = 125\text{ °C}$	-	3,5	-	mA
$I_{GES}$	$V_{GE} = 20\text{ V}$ , $V_{CE} = 0$	-	-	200	nA
$V_{CESat}$	$I_C = 50\text{ A}$ } $V_{GE} = 15\text{ V}$ ;	-	2,5(3,1)	3(3,7)	V
$V_{CESat}$	$I_C = 75\text{ A}$ } $T_j = 25\text{ (125) °C}$	-	3(3,8)	-	V
$g_{fs}$	$V_{CE} = 20\text{ V}$ , $I_C = 50\text{ A}$	23	40	-	S
$C_{CHC}$	per IGBT	-	-	350	pF
$C_{ies}$	$V_{GE} = 0$	-	3,3	4,3	nF
$C_{oes}$	$V_{CE} = 25\text{ V}$	-	500	600	pF
$C_{res}$	$f = 1\text{ MHz}$	-	220	300	pF
$L_{CE}$		-	-	30	nH
$t_{d(on)}$	$V_{CC} = 600\text{ V}$	-	44	100	ns
$t_r$	$V_{GE} = +15\text{ V}$ , $-15\text{ V}^3)$	-	56	100	ns
$t_{d(off)}$	$I_C = 50\text{ A}$ , ind. load	-	380	500	ns
$t_f$	$R_{Gon} = R_{Goff} = 22\ \Omega$	-	70	100	ns
$E_{on}^5)$	$T_j = 125\text{ °C}$	-	8	-	mWs
$E_{off}^5)$		-	5	-	mWs
Inverse Diode <sup>8)</sup>					
$V_F = V_{EC}$	$I_F = 50\text{ A}$ } $V_{GE} = 0\text{ V}$ ;	-	2,0(1,8)	2,5	V
$V_F = V_{EC}$	$I_F = 75\text{ A}$ } $T_j = 25\text{ (125) °C}$	-	2,25(2,1)	-	V
$V_{TO}$	$T_j = 125\text{ °C}$	-	-	1,2	V
$r_T$	$T_j = 125\text{ °C}$	-	18	22	mΩ
$I_{RRM}$	$I_F = 50\text{ A}$ ; $T_j = 25\text{ (125) °C}^2)$	-	23(35)	-	A
$Q_{rr}$	$I_F = 50\text{ A}$ ; $T_j = 25\text{ (125) °C}^2)$	-	2,3(7)	-	μC
FWD of types "GAL" and "GAR" <sup>8)</sup>					
$V_F = V_{EC}$	$I_F = 50\text{ A}$ } $V_{GE} = 0\text{ V}$ ;	-	1,85(1,6)	2,2	V
$V_F = V_{EC}$	$I_F = 75\text{ A}$ } $T_j = 25\text{ (125) °C}$	-	2,0(1,8)	-	V
$V_{TO}$	$T_j = 125\text{ °C}$	-	-	1,2	V
$r_T$	$T_j = 125\text{ °C}$	-	12	15	mΩ
$I_{RRM}$	$I_F = 50\text{ A}$ ; $T_j = 25\text{ (125) °C}^2)$	-	27(40)	-	A
$Q_{rr}$	$I_F = 50\text{ A}$ ; $T_j = 25\text{ (125) °C}^2)$	-	2,5(8)	-	μC
Thermal Characteristics					
$R_{thjc}$	per IGBT	-	-	0,27	°C/W
$R_{thjc}$	per diode / FWD "GAL"	-	-	0,60/0,50	°C/W
$R_{thch}$	per module	-	-	0,05	°C/W

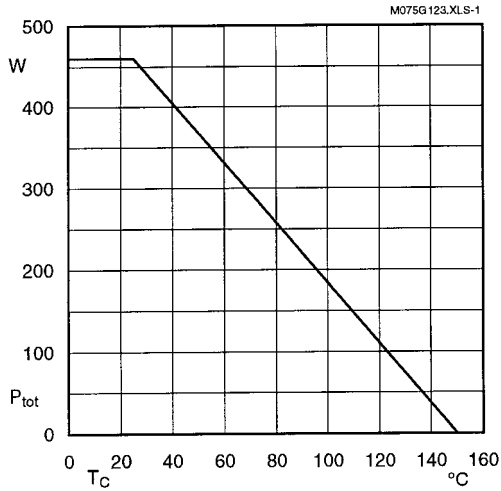

Fig. 1 Rated power dissipation  $P_{tot} = f(T_C)$

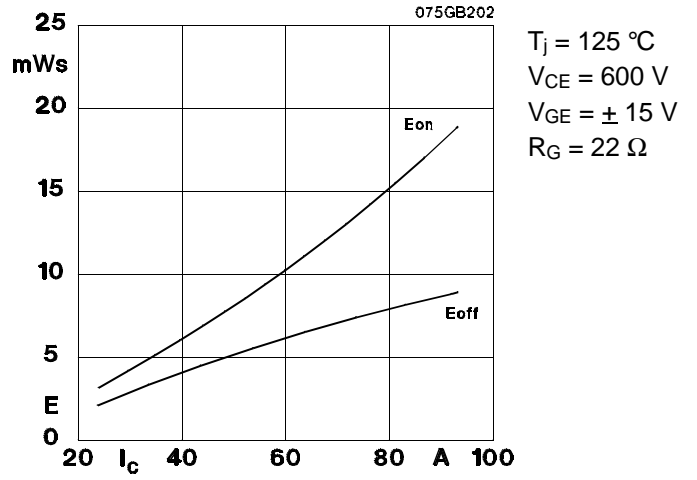

Fig. 2 Turn-on /-off energy  $= f(I_C)$

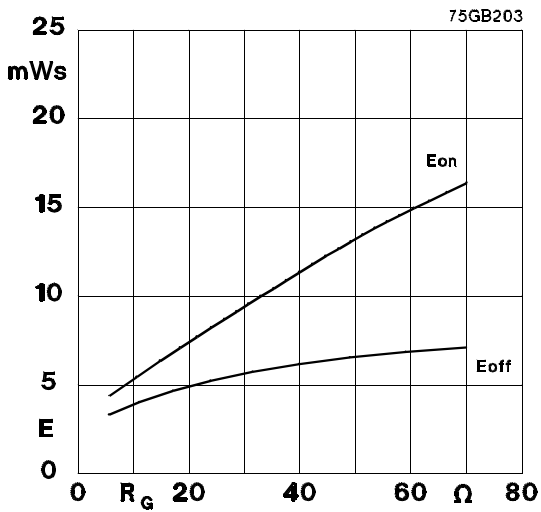

Fig. 3 Turn-on /-off energy  $= f(R_G)$

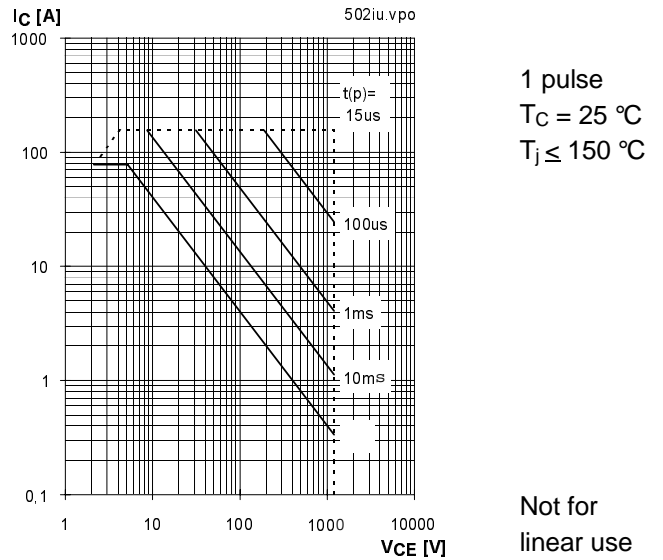

Fig. 4 Maximum safe operating area (SOA)  $I_C = f(V_{CE})$

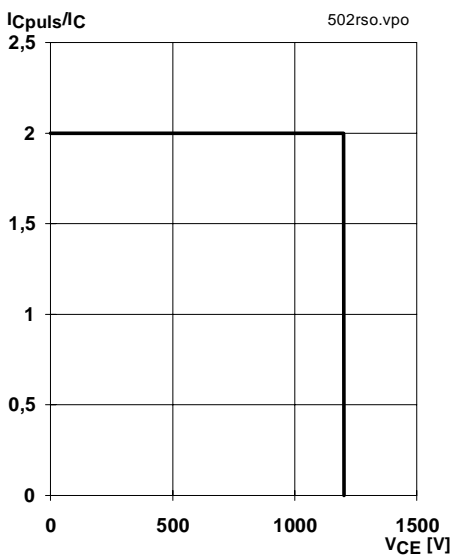

Fig. 5 Turn-off safe operating area (RBSOA)

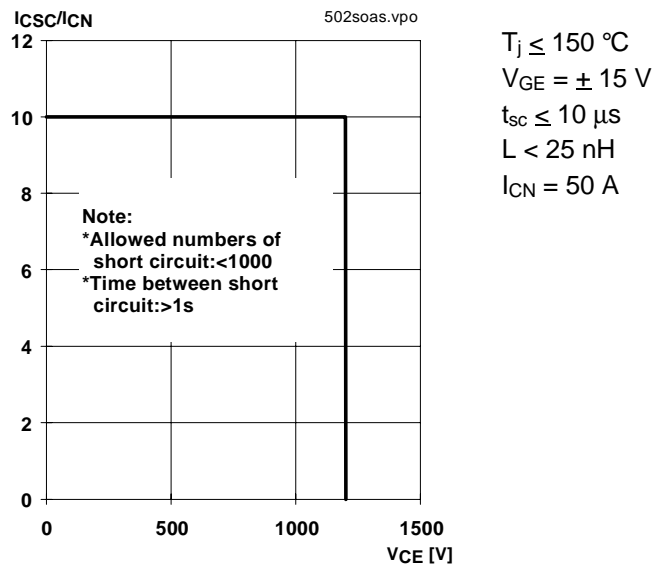

Fig. 6 Safe operating area at short circuit  $I_C = f(V_{CE})$

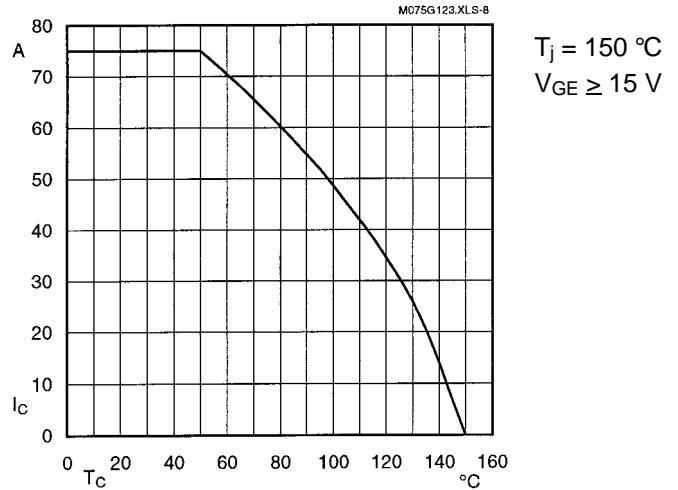

Fig. 8 Rated current vs. temperature  $I_c = f(T_c)$

Fig. 7 Short circuit current vs. turn-on gate voltage

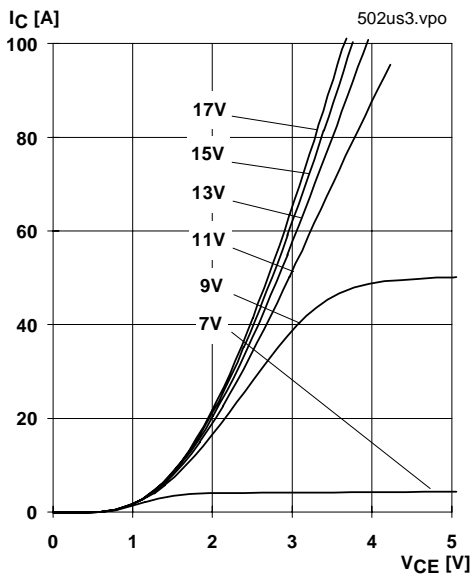

Fig. 9 Typ. output characteristic,  $t_p = 80 \mu s$ ;  $25 \text{ }^\circ\text{C}$

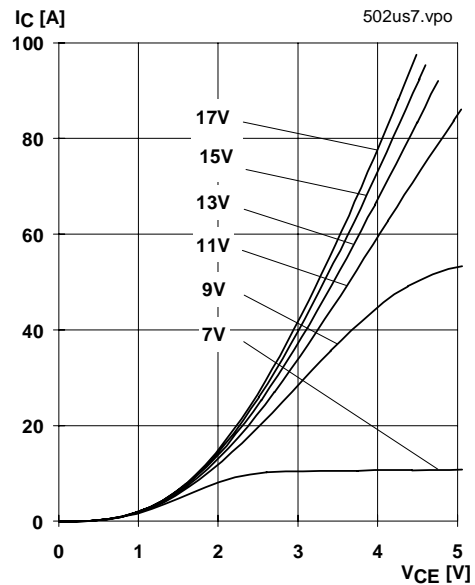

Fig. 10 Typ. output characteristic,  $t_p = 80 \mu s$ ;  $125 \text{ }^\circ\text{C}$

$$P_{cond(t)} = V_{CEsat(t)} \cdot I_{C(t)}$$

$$V_{CEsat(t)} = V_{CE(TO)(T_j)} + r_{CE(T_j)} \cdot I_{C(t)}$$

$$V_{CE(TO)(T_j)} \leq 1,5 + 0,002 (T_j - 25) \text{ [V]}$$

$$\text{typ.: } r_{CE(T_j)} = 0,020 + 0,00008 (T_j - 25) \text{ [\Omega]}$$

$$\text{max.: } r_{CE(T_j)} = 0,030 + 0,00010 (T_j - 25) \text{ [\Omega]}$$

$$\text{valid for } V_{GE} = +15 \frac{+2}{-1} \text{ [V]; } I_C \geq 0,3 I_{Cnom}$$

Fig. 11 Saturation characteristic (IGBT)  
Calculation elements and equations

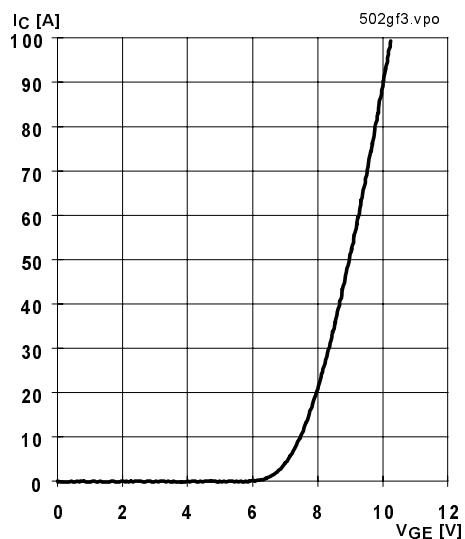

Fig. 12 Typ. transfer characteristic,  $t_p = 80 \mu s$ ;  $V_{CE} = 20 \text{ V}$

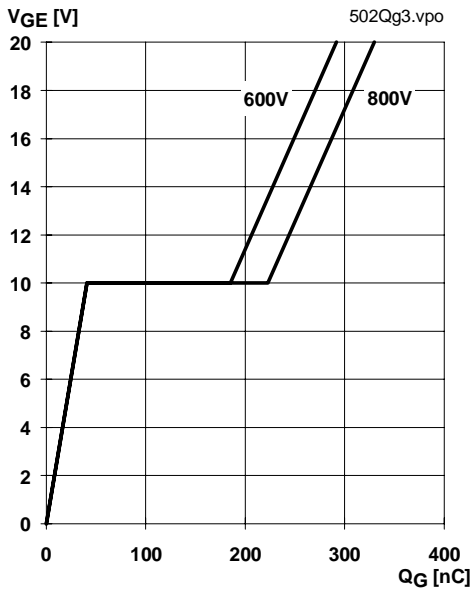

Fig. 13 Typ. gate charge characteristic

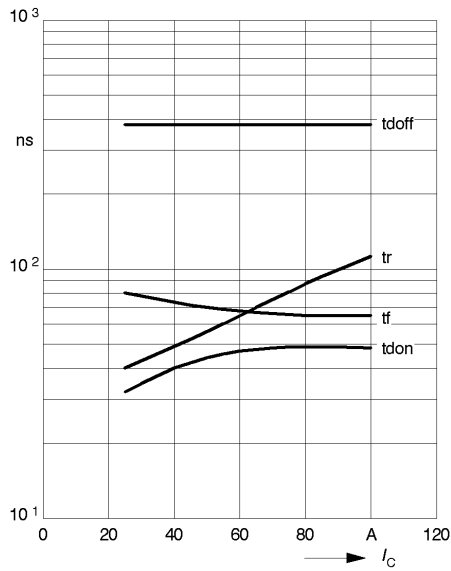

Fig. 15 Typ. switching times vs.  $I_C$

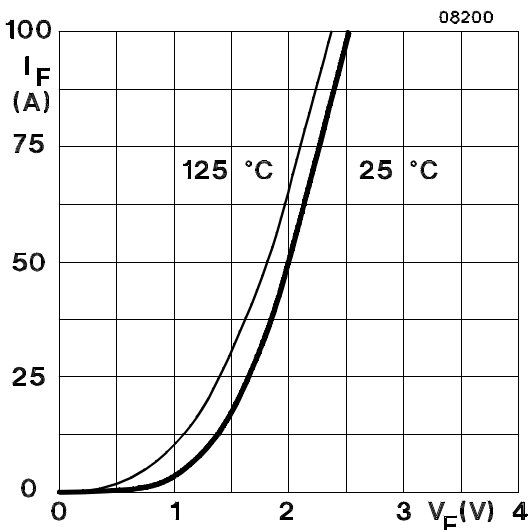

Fig. 17 Typ. CAL diode forward characteristic

$I_{Cpuls} = 50 \text{ A}$

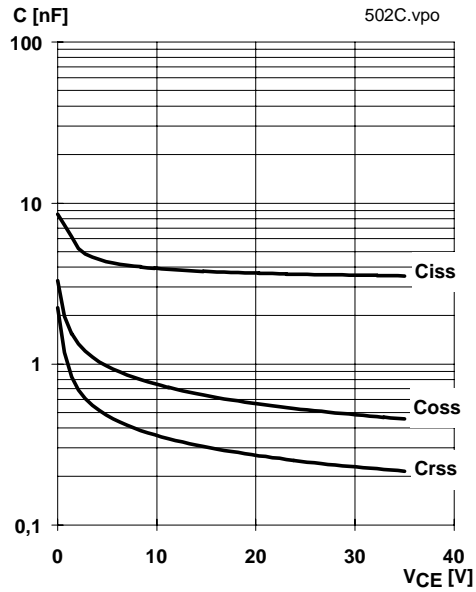

Fig. 14 Typ. capacitances vs.  $V_{CE}$

$V_{GE} = 0 \text{ V}$   
 $f = 1 \text{ MHz}$

$T_j = 125 \text{ }^\circ\text{C}$   
 $V_{CE} = 600 \text{ V}$   
 $V_{GE} = \pm 15 \text{ V}$   
 $R_{Gon} = 22 \text{ } \Omega$   
 $R_{Goff} = 22 \text{ } \Omega$   
induct. load

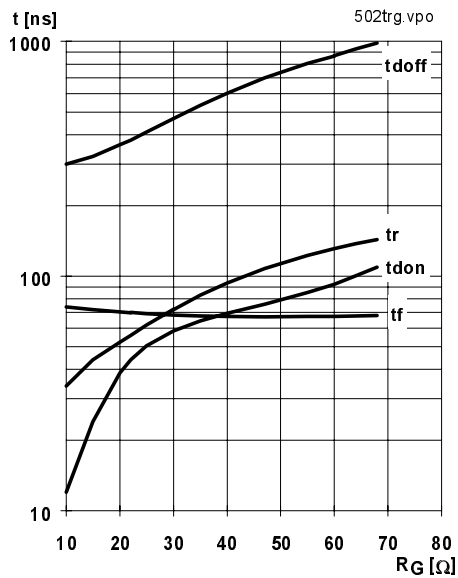

Fig. 16 Typ. switching times vs. gate resistor  $R_G$

$T_j = 125 \text{ }^\circ\text{C}$   
 $V_{CE} = 600 \text{ V}$   
 $V_{GE} = \pm 15 \text{ V}$   
 $I_C = 50 \text{ A}$   
induct. load

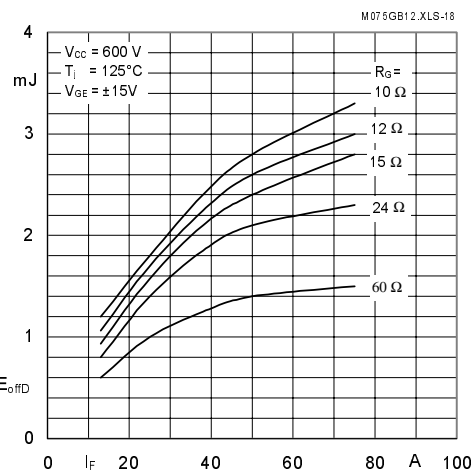

Fig. 18 Diode turn-off energy dissipation per pulse

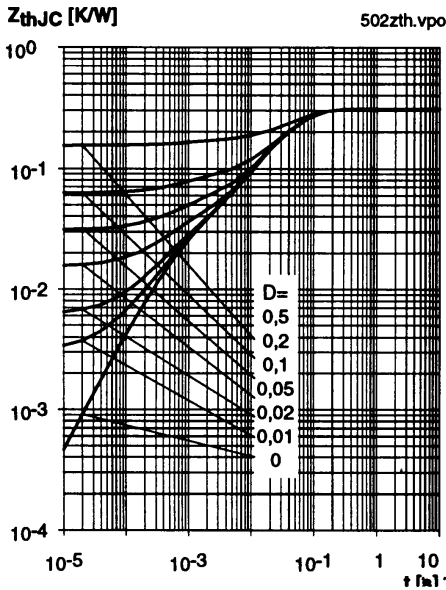

Fig. 19 Transient thermal impedance of IGBT  
 $Z_{thJC} = f(t_p)$ ;  $D = t_p / t_c = t_p \cdot f$

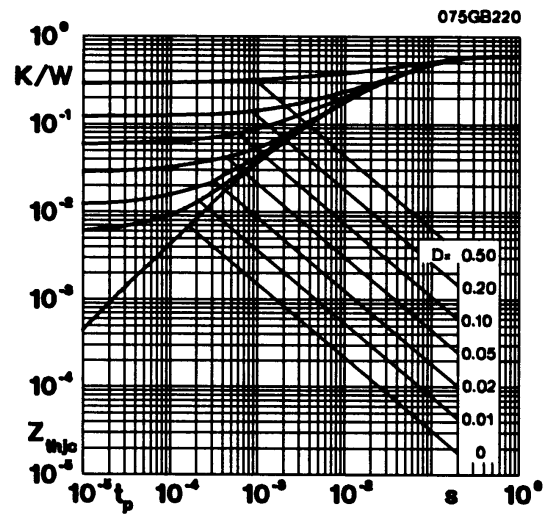

Fig. 20 Transient thermal impedance of inverse CAL diodes  
 $Z_{thJC} = f(t_p)$ ;  $D = t_p / t_c = t_p \cdot f$

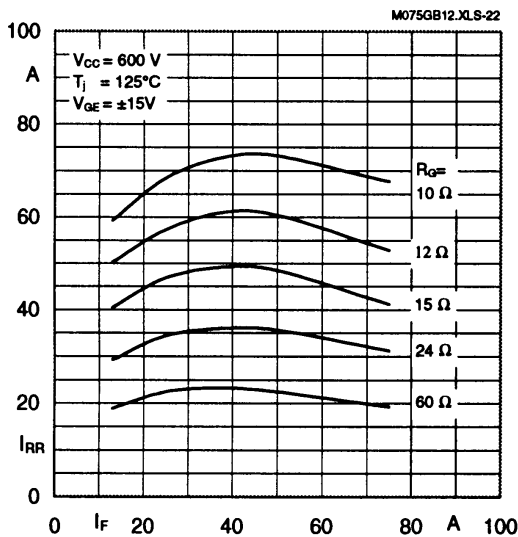

Fig. 22 Typ. CAL diode peak reverse recovery current  $I_{RR} = f(I_F; R_G)$

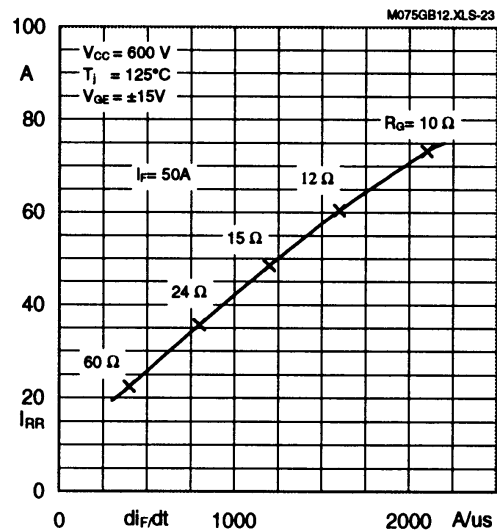

Fig. 23 Typ. CAL diode peak reverse recovery current  $I_{RR} = f(di/dt)$

## Typical Applications

### Include

- Switched mode power supplies
- DC servo and robot drives
- Inverters
- DC choppers (versions GAL)
- AC motor speed control
- Inductive heating
- UPS Uninterruptable power supplies
- General power switching applications
- Electronic (also portable) welders
- Pulse frequencies also above 15 kHz

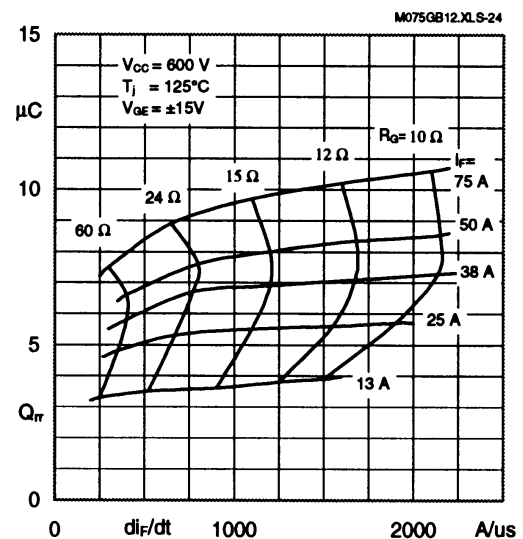

Fig. 24 Typ. CAL diode recovered charge  $Q_{rr} = f(di/dt)$

**SEMITRANS 2**

CASED61

Case D 61  
 UL Recognized  
 File no. E 63 532

SKM 75 GB 123 D  
 SKM 75 GB 173 D

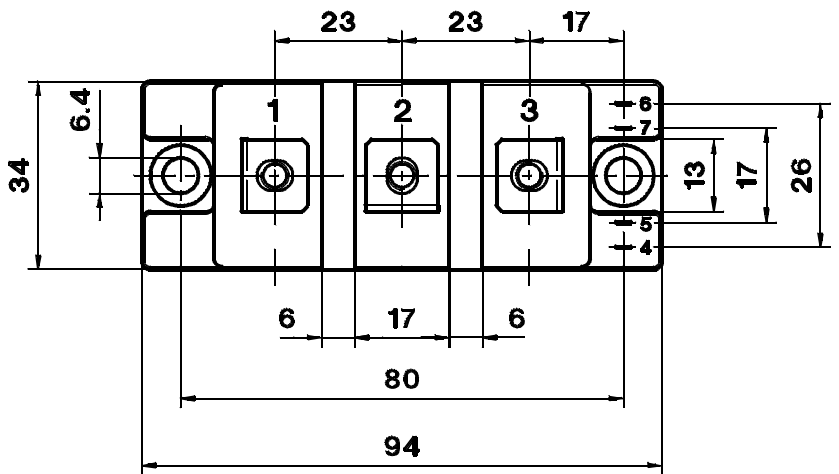
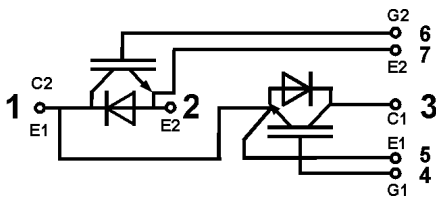
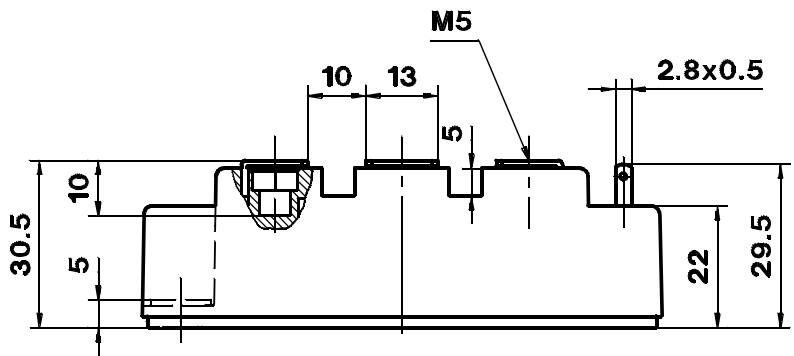

Dimensions in mm

**SKM 75 GAL 123 D**

Case D 62 (→ D 61)

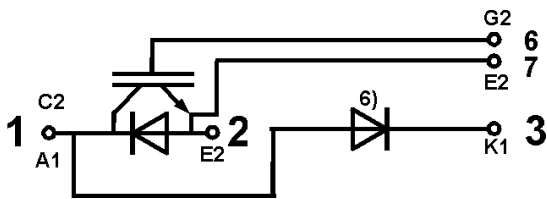

**SKM 75 GAR 123 D**

Case D 63 (→ D 61)

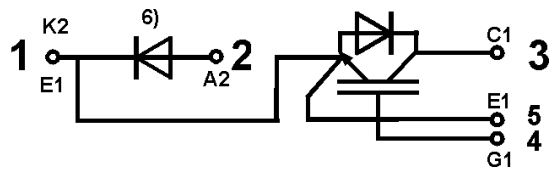

Case outline and circuit diagrams

Mechanical Data		Values			Units
Symbol	Conditions	min.	typ.	max.	
M <sub>1</sub>	to heatsink, SI Units	(M6) 3	—	5	Nm
	to heatsink, US Units	27	—	44	lb.in.
M <sub>2</sub>	for terminals, SI Units	(M5) 2,5	—	5	Nm
	for terminals US Units	22	—	44	lb.in.
a		—	—	5x9,81	m/s <sup>2</sup>
w		—	—	160	g

This is an electrostatic discharge sensitive device (ESDS). Please observe the international standard IEC 747-1, Chapter IX.

Eight devices are supplied in one SEMIBOX A without mounting hardware, which can be ordered separately under Ident No. 33321100 (for 10 SEMITRANS 2)  
 Accessories → B 6 – 4.  
 SEMIBOX → C – 1.  
 Larger packing units of 20 pieces are used if suitable.

<sup>6)</sup> Freewheeling diode → B 6 – 87, remark 6.